

ENTERPRISE SYSTEMTM
FOR BRICK-TIE CHANNELS

USER
INSTALLATION
GUIDE

www.enterprisesystem.co.uk

1.0 FOREWORD

1.1 Evolution Fasteners UK Ltd is a manufacturer of various fasteners and fixings for applications intended in the construction industry as well as aerospace, automotive and marine industries.

1.2 Evolution Fasteners UK Ltd is a UKAS (United Kingdom Accreditation Service) accredited testing laboratory. The laboratory holds accreditation to BS EN ISO/IEC 17025: 2017 and the UKAS Schedule of Accreditation is No. 74851.

1.3 Use of the National Accreditation Logo is in compliance with governmental regulations (HM Government: Department for Business, Energy & Industrial Strategy, 2018) and use of the ILAC (International Laboratory Accreditation Cooperation) MRA (Mutual Recognition Agreement) Logo is in compliance with ILAC regulations (International Laboratory Accreditation Cooperation, 2019).

1.4 Where data is presented from tests that are not included in our Schedule of Accreditation, they will be notated with "NC". Opinions and interpretations expressed herein are outside the scope of UKAS accreditation.

1.5 This document has been prepared by the Department of Engineering and Laboratory Services of Evolution Fasteners UK Ltd and takes a form (where possible) to conform with the general layout and conventions of ISO (International Standards Organisation) and CEN (Comité Européen de Normalisation) documents for the purposes of familiarity with readers.

1.6 This document is a copyright protected document published 2019 in the United Kingdom. This document shall not be reproduced except in full, without written approval of Evolution Fasteners UK Ltd. Results and data in this document relate only to the items stated alongside such data as the data is underpinned by empirical testing in our accredited laboratory.

1.7 This document is strictly provided without prejudice, without recourse, non-assumptist, errors and omissions excepted, no assured value, no liability and all rights reserved.



2.0 SCOPE

2.1 The purpose of this document is to inform users and installers of our product on the installation procedure for our fasteners and additional components in order to comply with the Evolution Product Warranty.

2.2 This document is strictly provided without prejudice, without recourse, non-assumptist, errors and omissions excepted, no assured value, no liability and all rights reserved.

2.3 The use of this document does not alleviate, absolve or otherwise relieve or diminish the user, designer or any other party from their respective obligations under the:

- (a) Building Regulations 2010,
- (b) Building (Amendment) Regulations 2018,
- (c) Construction (Design and Management) Regulations 2015,
- (d) Building Safety Act 2022,
- (e) Any other law, statute, statutory instrument, directive, regulation or otherwise.

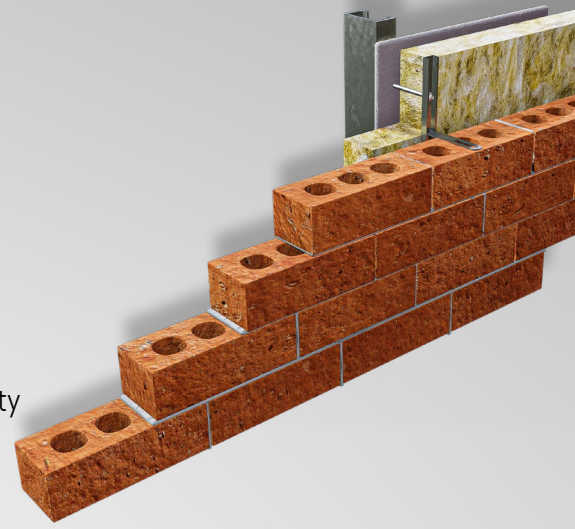

PRODUCTS FALLING WITHIN THE SCOPE OF THIS WARRANTY			
PRODUCT CHARACTERISTICS			USABILITY CONDITIONS
SS16	EN 1.4301	WEATHER-SEALING WASHER	C3

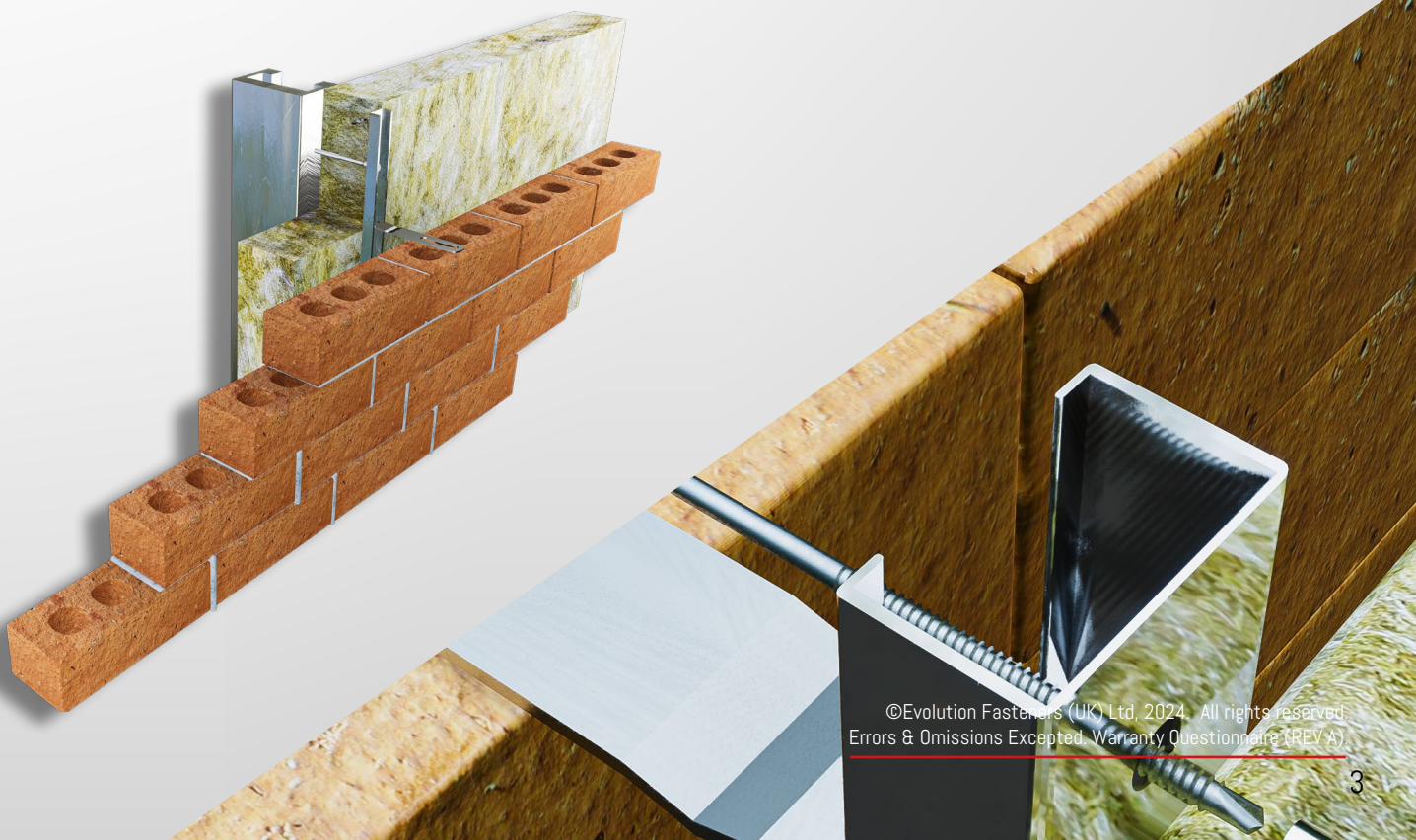

3.0 NORMATIVE REFERENCES

3.1 The following referenced documents are indispensable for the application of this document. For dated references, only the edition cited applies. For undated references, the latest edition of the referenced document (including any amendments) applies:

- (a) BS EN 166: 2002
Personal eye protection. Specifications.
- (b) BS EN 140: 1999
Respiratory protective devices. Half masks and quarter masks.
Requirements, testing and marking.
- (c) BS EN 14387: 2004 + A1: 2008
Respiratory protective devices. Gas filter(s) and combined filter(s).
Requirements, testing and marking.
- (d) BS EN 388: 2016
Protective gloves against mechanical risks.
- (e) BS EN ISO 3506-1: 2020
Fasteners. Mechanical properties of corrosion-resistant stainless-steel fasteners.
Part 1: Bolts, screws and studs with specified grades and property classes.
- (f) BS EN 10088-2: 2014
Stainless-steels. Technical delivery conditions for sheet/ plate and strip of
corrosion-resisting steels for general purposes.
- (g) Approved Document A
The Building Regulations 2010. Structure. Approved Document A. 2024 Edition.
- (h) Statutory Instrument 2010 No. 2214
The Building Regulations 2010.
- (i) BS EN 845-1: 2013 + A1: 2016
Specification for ancillary components for masonry. Wall ties, tension straps, hangers and
brackets.
- (j) NHBC Standards 2024
National House Building Council. Standards. 2024 Edition.
- (k) PD 6697: 2019 – TC
Recommendations for the design of masonry structures to BS EN 1996-1-1 and BS EN 1996-2.
- (l) BS EN 1991-1-4: 2005 + A1: 2010
Eurocode 1. Actions on structures. General actions. Wind actions.
- (m) BS EN 14195: 2014
Metal framing components for gypsum board systems.
Definitions, requirements and test methods.

4.0 REQUIRED EQUIPMENT AND APPARATUS

4.1 Personal Protective Equipment (PPE):

- a) Eyeglasses meeting BS EN 166: 2002 Class 1F (or better)
- b) Dust mask with face piece meeting BS EN 140: 1999 and filters meeting BS EN 14387: 2004 & A1:2008 (or better)
- c) Safety gloves meeting BS EN 388: 2016 (or better).

4.2 Power Tools:

- d) Standard TEK screwdriver (non-impacting) such as Makita® FS2500
- e) Standard rotary hammer-action drill for drilling pilot holes in masonry or concrete.

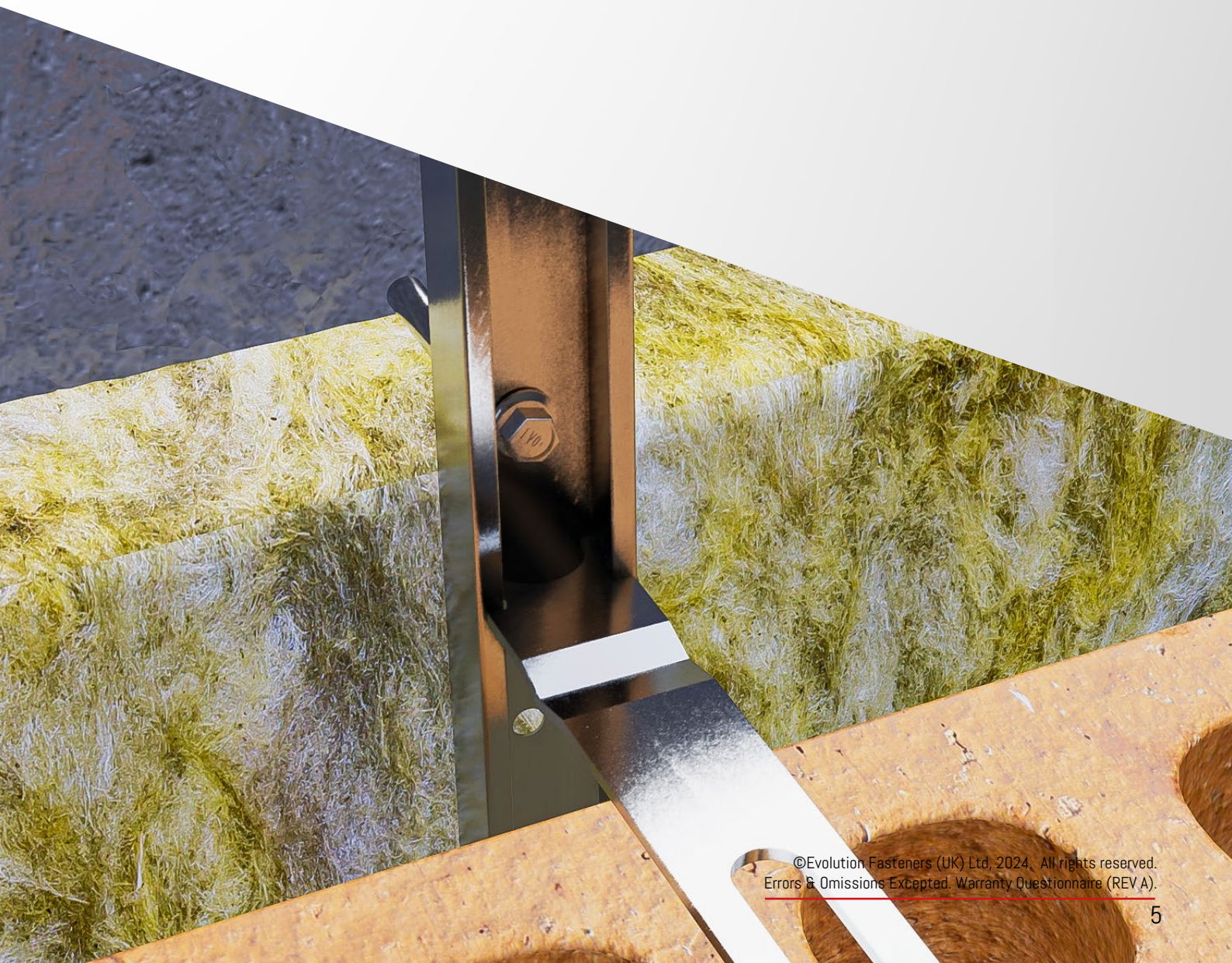

5.0 MATERIALS AND COMPONENTS

5.1 SUBSTRATES

5.1.1 The term 'substate' refers to any solid substance to which another substance is applied so that the second substance adheres to the substrate.

5.1.2 Evolution Fasteners products can be used to restrain the wall-tie system back to mild steel substrates of thicknesses varying from 1.2 to 4.0mm for cold-rolled SFS (Structural Framing Systems) or IFW (In-Fill Walling) sections as well as 4.0mm to 12.0mm hot-rolled sections pursuant to Table 02.

RECOMMENDED FIXING TYPES TO COLD AND HOT-ROLLED MILD STRUCTURAL STEEL SUBSTRATES		
STEEL NOM. THICKNESS (mm)	SUBSTRATE TYPE	RECOMMENDED PRODUCT TYPE
1.20 TO 4.00	COLD-ROLLED OR EXTRUDED MILD STRUCTURAL STEEL SECTIONS	BMHT12-3, BMTSBWHT-3 A2BMHT-3 A4BMHT-3.
4.00 TO 12.00	HOT-ROLLED MILD STRUCTURAL STEEL SECTIONS	BMTSBWHT-5

5.1.3 Evolution Fasteners products can be used to restrain the wall-tie system back to un-cracked concrete, cracked concrete or high-density masonry blocks pursuant to Table 03:

RECOMMENDED FIXING TYPES TO CONCRETE AND MASONRY SUBSTRATES	
SUBSTRATE TYPE	RECOMMENDED PRODUCT TYPE
CRACKED CONCRETE	A4HH.
UN-CRACKED CONCRETE	A4HH, CSTCS (REDUCED WARRANTY).
HIGH-DENSITY MASONRY	A4HH, CSTCS (REDUCED WARRANTY).

5.1 SHEATHING BOARDS

5.2.1 In the construction industry, the term 'sheathing', or 'sheathing board' can be used to refer to a layer of board or panel material that forms a part of floor, wall and roof assemblies.

The outer sheathing board strengthens the assembly, provides a surface for other materials to be applied and may give some degree of weather resistance.

5.2.2 Sheathing boards typically used in conjunction with this system include:

- (a) OSB (Orientated Strand Board)
- (b) CP (Cement Particle) Board

5.2.3 To confirm the suitability of your sheathing boards in-conjunction with this system, please contact technical@evofas.com for confirmation.

5.3 RIGID, SEMI-RIGID AND NON-RIGID INSULATION

5.3.1 Insulation materials have a low thermal conductivity which serves to limit the flow of heat energy between one side of the insulation and the other. In construction insulation is typically used to reduce the passage of heat between the inside of a building and the outside.

5.3.2 Rigid insulation/ foam boards such as PIR are rigid panels of insulation which are cut and fit in place. Most commonly they are made from polystyrene, polyisocyanurate and polyurethane. The benefits of foam boards are that they are durable and can also provide acoustic insulation they can also be used without the requirement of a compression sleeve as the material will not be as susceptible to compression.

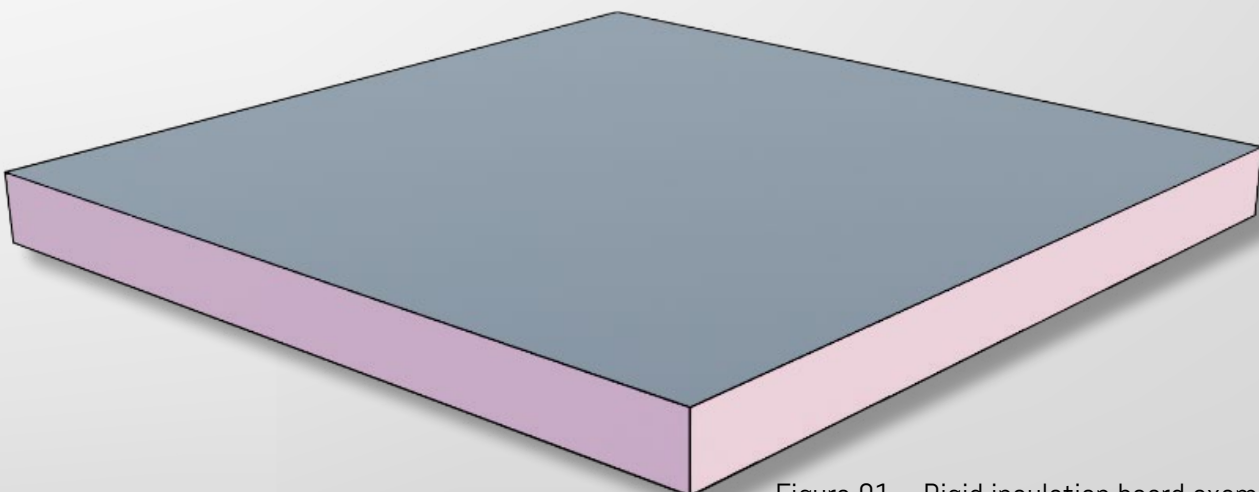

Figure 01 – Rigid insulation board example

5.3.3 Semi-rigid and non-rigid insulation is generally the easiest to install as it typically comes in rolls or battens for easy placement. This insulation is usually made from mineral or glass wool but can also be made from plastic fibres and natural fibres such as cotton and sheep's wool. The depth of blanket-style insulation varies depending on the exact composition and the performance required. This insulation can require compression sleeves to prevent the material from compressing under the force of the fastener.

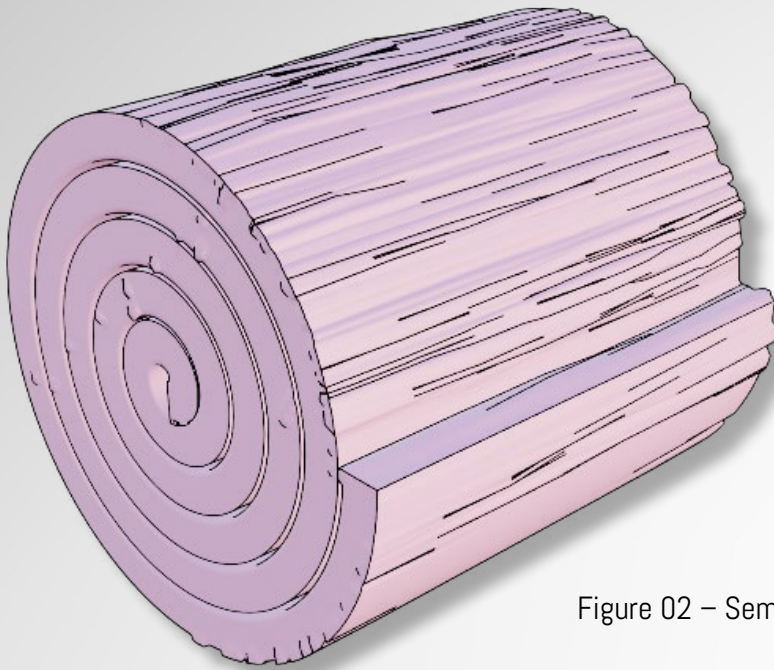

Figure 02 – Semi-rigid/ non-rigid insulation example

5.4 ANTI-COMPRESSSION SLEEVES

5.4.1 The use of a compression sleeve prevents the brick-tie system from having excessive movement during installation. The use of compression sleeves also prevents the insulation from compressing which can lead to cracking within the façade and the reductions of the 'U-value'.

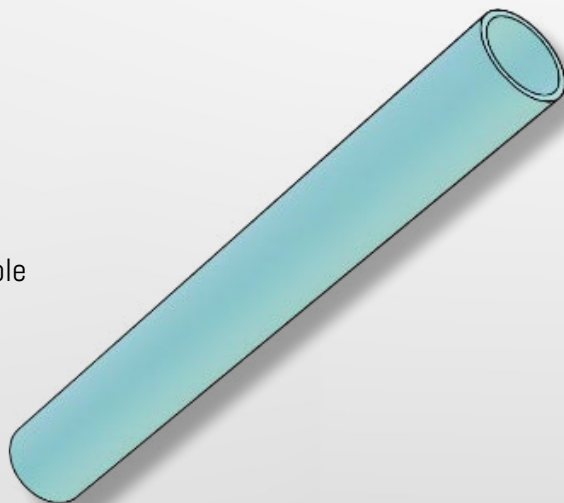

Figure 03 – Anti-compression sleeve example

5.5 FASTENERS

5.5.1 Fasteners are used to fix through the 25/14 wall-tie retention channel, through the insulation and sheathing boards into the final substrate and provide the overall connection of the system.

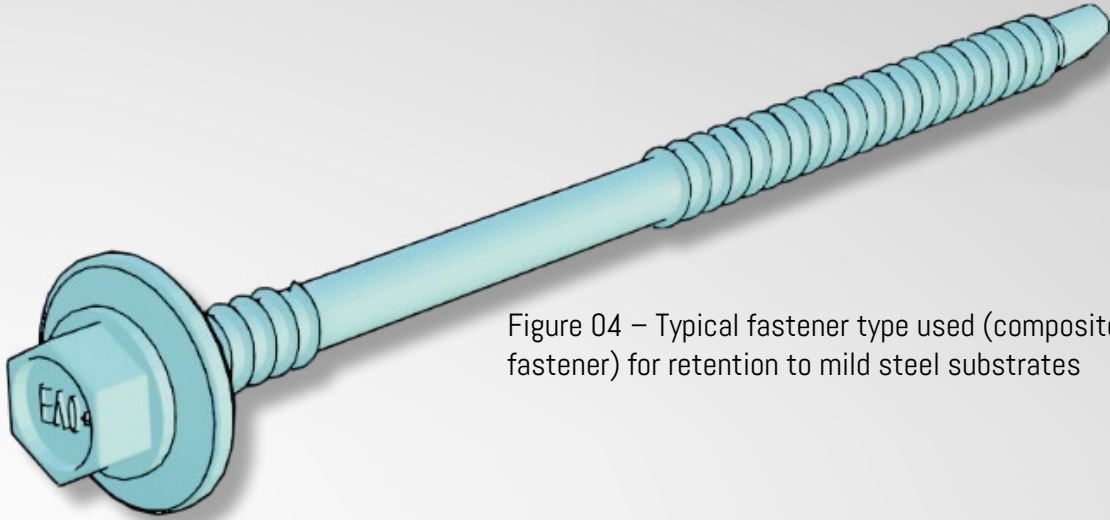

Figure 04 – Typical fastener type used (composite panel fastener) for retention to mild steel substrates

5.6 WALL-TIES

5.6.1 Wall-ties slot into the 25/14 channel and are secured to the outer leaf of the building via mortar joints. Wall-ties perform three primary functions; provide a connection, transfer lateral loads and permit in-plane movement to accommodate differential movement.

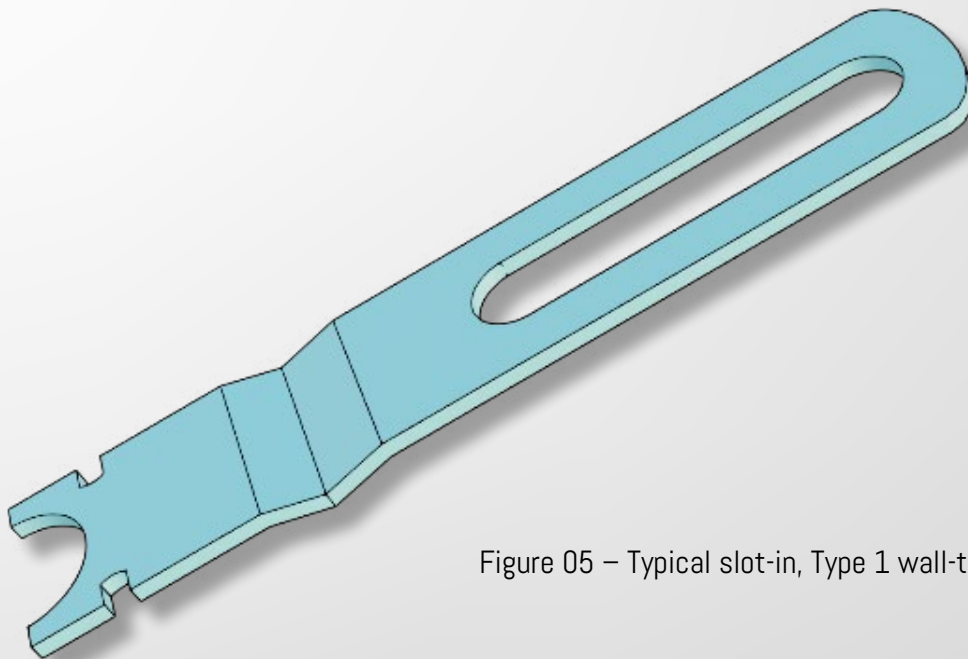

Figure 05 – Typical slot-in, Type 1 wall-tie

5.7 5/14 WALL-TIE RETENTION CHANNEL

5.7.1 The 25/14 channel allows the brick-tie to have vertical movement and a secure connection to both the inner and outer leaf of the building. The channel allows the slotted wall-tie to function in steel, concrete and timber structures.

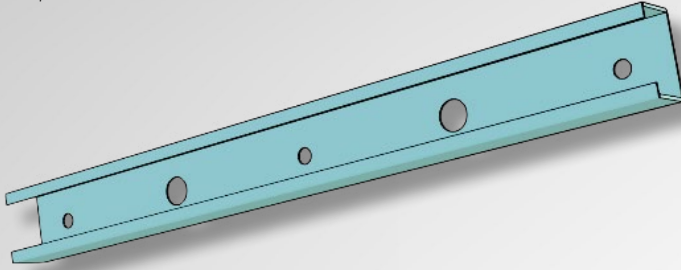

Figure 06 – Isometric view of typical 25/14 wall-tie retention channel

5.8 NYLON SHOULDER WASHER

5.8.1 Nylon shoulder washers are used to insulate the carbon steel fastener from the stainless-steel compression sleeve, preventing bi-metallic corrosion.

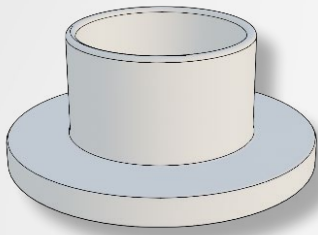

Figure 07 – Example of nylon shoulder washer

5.9 EPDM WEATHER-SEALING WASHER

5.8.1 Washers comprise an EPDM (XXX) gasket bonded to an EN 1.4301 stainless-steel compression disc. The purpose of the washer is to further resist pull-through failure as well as aid in the prevention of water ingress through the voids inside anti-compression sleeves.

Figure 08 – Example of an EPDM weather-sealing washer

6.0 INSTALLATION PROCEDURES

6.1 ANTI-COMPRESSION SLEEVE INSTALLATION

6.1.1 The anti-compression sleeves are installed by manual insertion into the insulation until the anti-compression sleeve is set flush with the surface of the insulation.
Failure to ensure proper setting of the anti-compression sleeves will invalidate the warranty.

6.1.2 The anti-compression sleeves are to be installed perpendicularly with respect to the surface of the sheathing boards with an acceptable deviation from normal being $\pm 5.0^\circ$.
A deviation from normal outwith these conditions will invalidate the warranty.



Figure 08 –
Installation of anti-compression sleeves

6.1.3 Best practice, as recommended by Evolution Fasteners UK Ltd, is to use anti-compression sleeves in all applications regardless of the insulation type (rigid, semi-rigid or non-rigid) or the thickness of the insulation.

6.1.4 Acceptable practice, is for anti-compression sleeves to be used as noted below.
Failure to adhere to the minimum acceptable practice will invalidate the warranty:

- (a) When fixing through rigid insulation, a compression sleeve must be used when thickness of such insulation exceeds 220.0mm.
- (b) When fixing through semi-rigid insulation, a compression sleeve must be used in all thicknesses of insulation, except in the exempted insulations noted below. In these exempted insulations, a compression sleeve is only mandated when the thickness is equal to (or greater than) 180.0mm:
 - (I) Isover Poltern Max Plus
 - (II) Kingspan Facades K-Roc Rainscreen Slab
 - (III) ROCKWOOL Nyrock Rainscreen 032
 - (IV) ROCKWOOL Rainscreen Duo Slab
 - (V) Unilin Insulated Stonewool SW/RS
- (c) When fixing through non-rigid insulation, an anti-compression sleeve must be used in all thicknesses of insulation.

6.2 NYLON SHOULDER WASHER INSTALLATION

6.2.1 The nylon shoulder washer is installed into the larger diameter hole in the 25/14 channel and inserts inside the mouth of the anti-compression sleeves. Failure to adequately set nylon shoulder washers into the anti-compression sleeves will invalidate the warranty.



Figure 09 – Seating of nylon shoulder washers



6.2.2 Best practice, as recommended by Evolution Fasteners, is to always use nylon shoulder washers, regardless of the fastener type used.

6.2.3 Acceptable practice, is for nylon shoulder washers to be used when CSTCS fasteners are used to retain the channels back to concrete and masonry substrates.

Failure to use nylon shoulder washers with CSTCS will invalidate the warranty.

6.3 FASTENER INSTALLATION FOR MILD STRUCTURAL STEEL SUBSTRATES

- 6.3.1 Clear the installation area of dirt and debris and ensure that there are no other contamination substances such as oil, grease, etc,
- 6.3.2 Insert selected stainless steel compression sleeve through insulation at appropriate centres to align with the pre-drilled hole of the 25/14 channel until the compression sleeve is fully embedded into the insulation.
- 6.3.3 Place the 25/14 channel over the compression sleeves and insert nylon shoulder washer through the pre-drilled holes of the 25/14 channel into the compression sleeve.
- 6.3.4 Using an approved power tool, drive the fixture through the pre-drilled holes in the 25/14 channel and compression with the screws being installed perpendicularly (within $\pm 5^\circ$ to the normal) to the fixture and substrate and continue to drive the fastener until the bonded washer of the screw is in contact with the surface of the 25/14 channel ensuring that EPDM washers do not deform or tear. Failure to install fasteners within perpendicularity conditions will invalidate the warranty. Failure to install fasteners without damaging the EPDM washers will invalidate the warranty.



Figure 10 – Installation of fasteners for retention of wall-tie system to mild structural steels

6.4 FASTENER INSTALLATION FOR CONCRETE AND MASONRY SUBSTRATES

6.4.1 Ensure environmental conditions are correct for use and installation of the product, specifically (list is not exhaustive) that:

- (a) The products are being used in a dry and internal place
- (b) The products are being used in the correct application as per the limitations

6.4.2 Ensure that substrate and fixture meet the requirements and specifications of relevant clauses in ETA-13/0634

6.4.3 Clear the installation area of dirt and debris and ensure that there are no other contaminating substances such as oil, grease, etc

6.4.4 Using a PGM® Approved "Special Drive System" (SDS™) drill bit (for masonry/ concrete) with a certified diameter of 6.0mm in conjunction with an appropriate SDS™ chucked Rotary Hammer Drill (110V corded such as Bosch GBH 3-28, or, 18V cordless such as Bosch GB18V-20); drill a pilot hole into the masonry substrate through the compression sleeve so that:

- (a) The pilot hole is drilled perpendicularly (within $\pm 5.0^\circ$ of normal) to the substrate, and,
- (b) The pilot hole is drilled to the minimum embedment depth as defined in ETA-13/0634 with a 5.0mm further drilling length to provide relief for fines and silts to rest in (without influencing the fixing)



Figure11 – Drilling of pilot hole

6.4.5 Using a blow-out pump (or compressed air jet with a minimum supply pressure of 8 bar) blow out debris from the pilot hole

6.4.6 Using a 6.0mm wire brush remove debris from the pilot hole

6.4.7 Insert selected stainless steel compression sleeve through insulation at appropriate centres to align with the pre-drilled hole of the 25/14 channel until the compression sleeve is fully embedded into the insulation.

6.4.8 Place the 25/14 channel over the compression sleeves and insert nylon shoulder washer through pre-drilled holes of 25/14 channel into compression sleeve.

6.4.9 Insert the fastener into the 25/14 channel hole, through the compression sleeve and using a non-impacting tool, tighten until the underside of the fastener is in contact with the surface of the 25/14 channel.



Figure 12 - Installation of fasteners for retention of wall-tie system to concrete or masonry

6.4.10 Best practice, as recommended by Evolution Fasteners, is to always use A4HH products when fastening to concrete or masonry substrates.

6.4.11 Acceptable practice, is to use either A4HH or CSTCS to fasten to concrete or masonry substrates, except where the concrete is cracked, in which case A4HH must be used. Failure to use A4HH in cracked concrete will invalidate the product warranty.

When using CSTCS in un-cracked or masonry, there is a penalty applied to the warranted period due to the use of non-stainless-steel products pursuant to Table 04:

WARRANTED PERIODS DEPENDING ON FASTENER SELECTED		
PRODUCT TYPE	SUBSTRATE	WARRANTED PERIOD
A4HH	MASONRY	50 YEARS
	UN-CRACKED CONCRETE	50 YEARS
	CRACKED CONCRETE	50 YEARS
CSTCS	MASONRY	25 YEARS
	UN-CRACKED CONCRETE	25 YEARS
	CRACKED CONCRETE	PROHIBITED

6.5 WALL-TIE INSTALLATION

6.5.1 Slotted brick-ties are inserted by rotating the tie by 90° and inserting into the 25/14 channel, the tie is then rotated back 90° so that the tie can only move in a vertical direction.



Figure 13 – Installation of wall-ties into retention channel

(END OF DOCUMENT)

T: +44 (0)141 647 7100/
CONTACT HERE: E:sales@evofas.com
E:technical@evofas.com

TECHNICAL CONSULTANCY SERVICES

In addition to manufacturing and distributing a wide range of premium quality fasteners, we also offer Technical Consultancy Services to support our products including the design and manufacture of bespoke fasteners.

WE BELIEVE IN FREE

Our expert team of structural, civil, mechanical, and chemical engineers are always on hand to offer FREE assistance and help when specifying or using our products.

QUALITY ASSURANCE AND LABORATORY TESTING



We operate a **UKAS accredited testing laboratory**, uniquely designed to test all aspects of construction fixings and fasteners as well as other tests suited to the aerospace, automotive, oil & gas, and marine industries.

OUR MOST SOUGHT AFTER SERVICES:

- TENSILE, SHEAR, FATIGUE AND DEFLECTION TESTING
- TORQUE TESTING
- FAILURE ANALYSIS (hydrogen embrittlement, stress corrosion etc)
- METALOGRAPHY (hardness - vickers/rockwell, HAZ etc)
- MICROSCOPY (light, metallographic etc)
- CORROSION TESTING (neutral salt spray, cyclic corrosion etc)



Premium quality is something we take very seriously at Evolution and our ISO 9001 certification demonstrates this. We are dedicated to ensuring quality in everything we do, from our products to our Customer Services and Marketing Support.

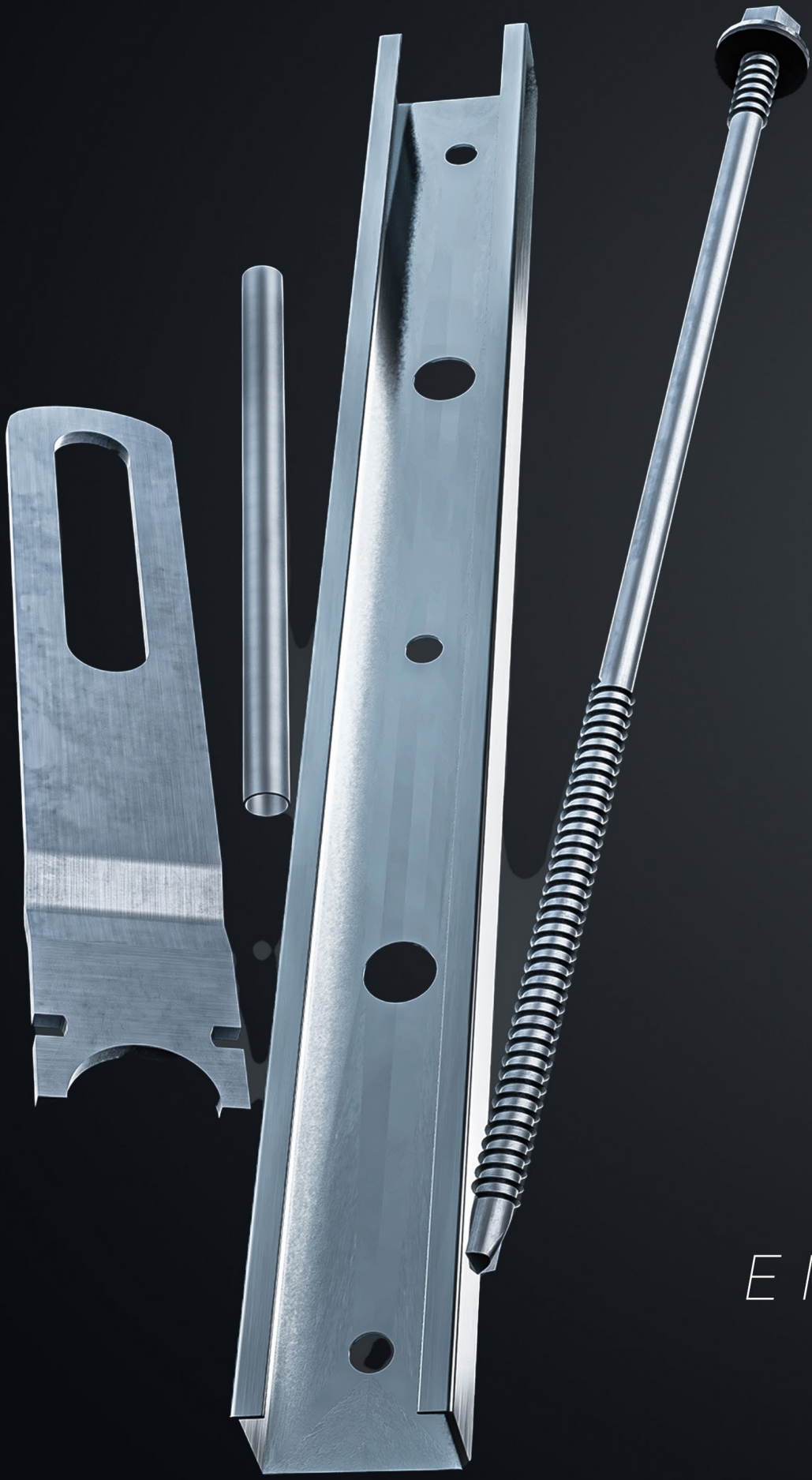

ENTERPRISE
FOR BR

WWW.ENTERPRISE



SE SYSTEMTM
TICK-TIE CHANNELS

SESYSTEM.CO.UK

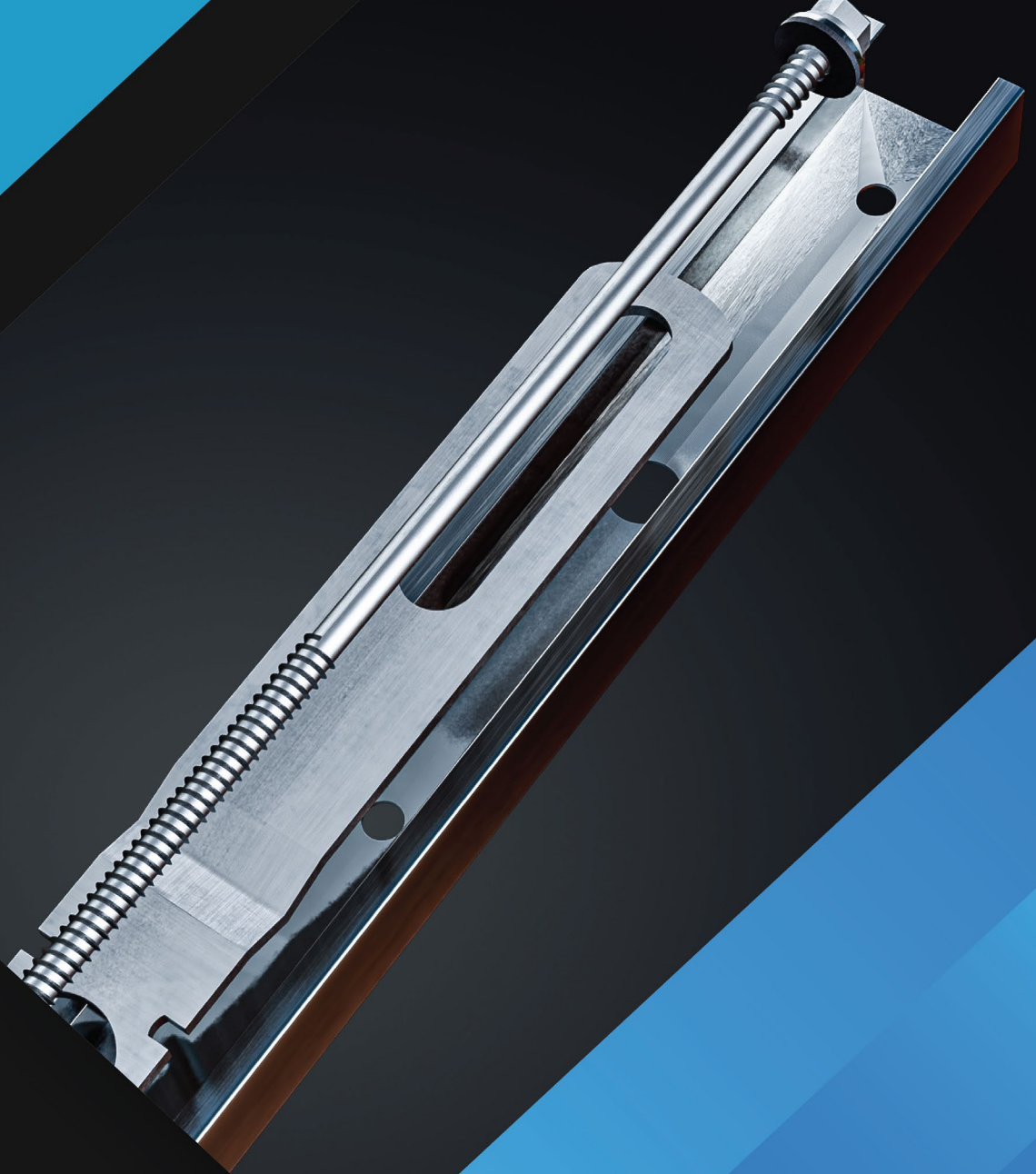

T: +44 (0)141 647 7100/

E:sales@evofas.com

E:technical@evofas.com



www.enterprisesystem.co.uk