



ENTERPRISE SYSTEMTM
FOR BRICK-TIE CHANNELS

www.enterprisesystem.co.uk

THE MAIN COMPONENTS OF THE



BRICK-TIE CHANNEL SYSTEM

GOLDEN THREAD READY.®

Our new Enterprise Brick-tie system™ is designed to be golden thread ready, aligning with best practices in modern construction. This means that our system is fully compliant with the highest standards of transparency, traceability, and accountability throughout its life-cycle.

By integrating the Enterprise Brick-tie system™ into your projects, you ensure a seamless flow of information and a robust, reliable construction process that meets the rigorous demands of today's building industry.

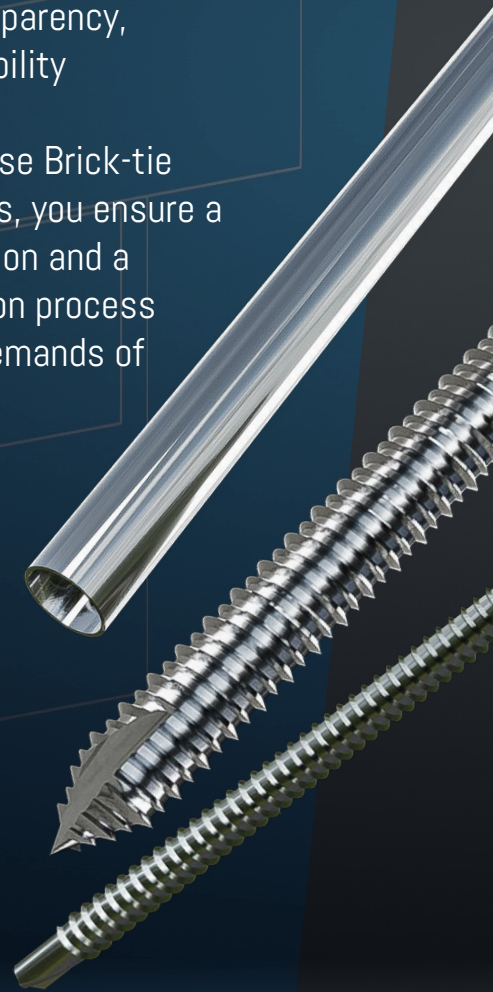

60 YEAR WARRANTY.

Our new Enterprise Brick-tie system™ comes with an impressive 60-year warranty, underscoring our confidence in its durability and performance. This extensive warranty ensures long-term reliability and peace of mind, reflecting our commitment to delivering high-quality, dependable products.

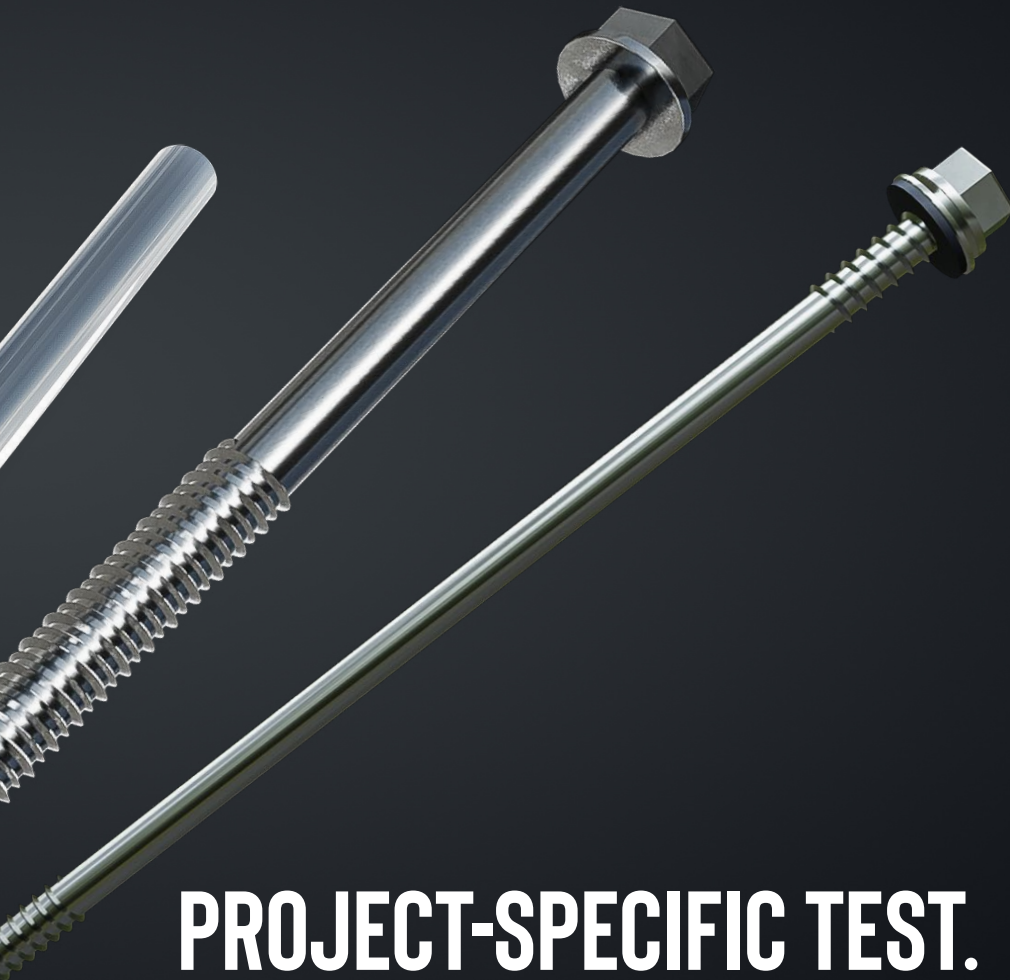

PROJECT-SPECIFIC TEST.

With every order of our new Enterprise Brick-tie system™, you will receive a test report from our UKAS-accredited laboratory, along with video footage as proof of the testing process. This comprehensive documentation ensures that you have verifiable evidence of the system's performance and reliability, demonstrating our commitment to quality and transparency.



BI-METAL™ COMPOSITE PANEL RANGE (LIGHT SECTION)

BMHT12* RANGE

PERFECT CHOICE
FOR OUR
BRICK TIE SYSTEM
THROUGH LIGHT
GAUGE STEEL

TEK 3® POINT FOR
1.2-4.0mm
STEEL THICKNESS

FOR LIGHT
STEEL

WITH 12mm
WASHER

FULL RANGE FROM:
5.5mm-
105mm to 350mm

RANGE:

BMHT12-5.5-105-3	BMHT12-5.5-135-3
BMHT12-5.5-150-3	BMHT12-5.5-185-3
BMHT12-5.5-200-3	BMHT12-5.5-225-3
BMHT12-5.5-235-3	BMHT12-5.5-265-3
BMHT12-5.5-275-3	BMHT12-5.5-300-3
BMHT12-5.5-325-3	BMHT12-5.5-350-3

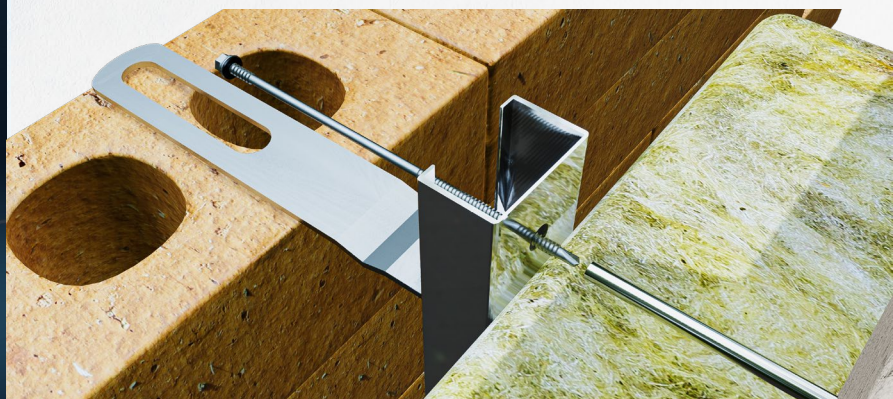
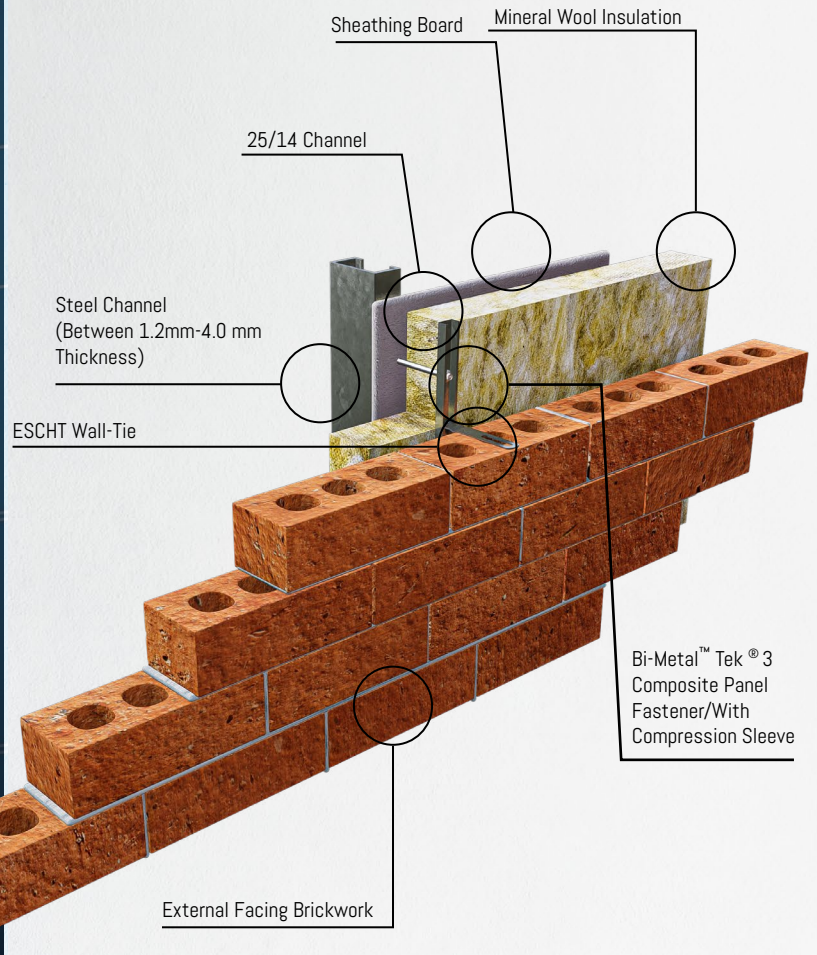

*RANGE CONTINUED
ON PAGE 15

FOR CONCRETE	A4 GRADE	FULL RANGE FROM: 6.3mm- 32mm to 250mm
-----------------	----------	---

RANGE:

A4HH6.3-32-GP	A4HH6.3-45-GP
A4HH6.3-57-GP	A4HH6.3-70-GP
A4HH6.3-82-GP	A4HH6.3-100-GP
A4HH6.3-125-GP	A4HH6.3-140-GP
A4HH6.3-160-GP	A4HH6.3-180-GP
A4HH6.3-200-GP	A4HH6.3-250-GP

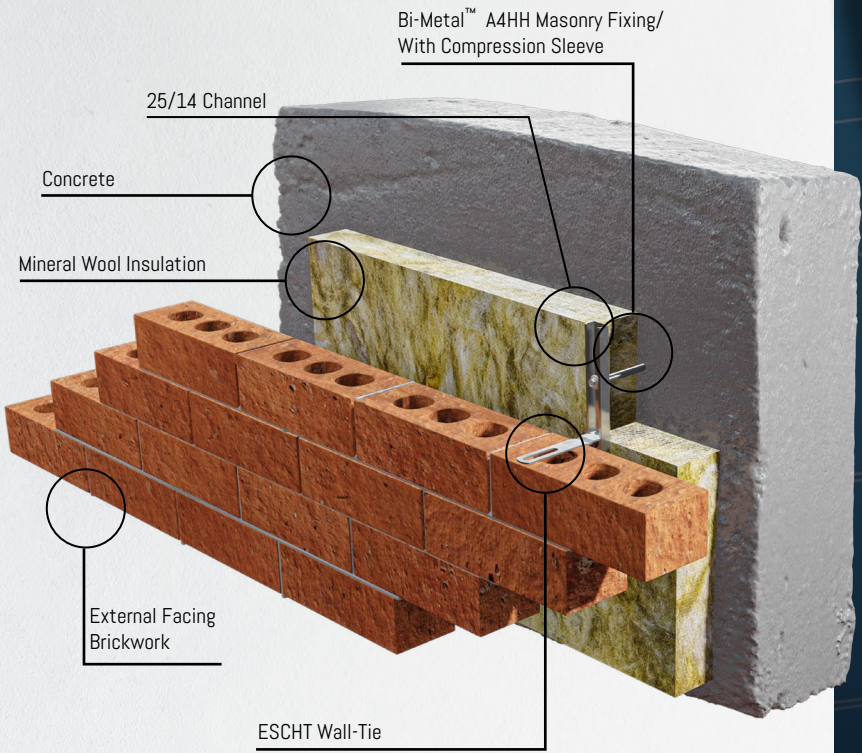

**BI-METAL™
MASONRY RANGE**

A4HH* RANGE

**PERFECT CHOICE
FOR OUR
BRICK TIE SYSTEM
THROUGH CONCRETE**

**EPDM 16.0mm
A4 STAINLESS STEEL
BONDED WASHERS OR
SHOULDER WASHER REQUIRED**



*FIXTURE BUILD-UP DATA
ON PAGE 21

TIE LENGTHS



Wall-Tie SKU	Size
ESCHT-100	100mm
ESCHT-125	125mm
ESCHT-150	150mm
ESCHT-175	175mm
ESCHT-200	200mm
ESCHT-225	225mm
ESCHT-250	250mm
ESCHT-275	275mm
ESCHT-300	300mm

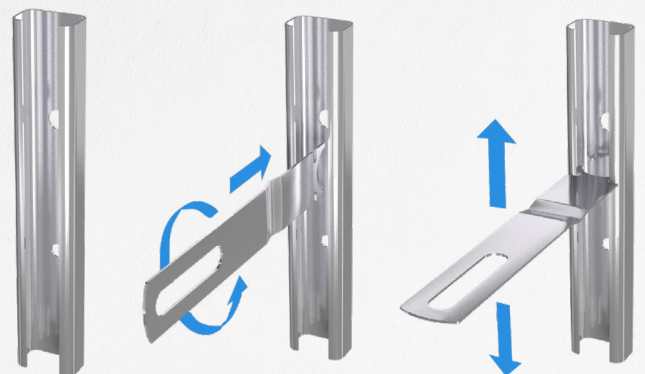
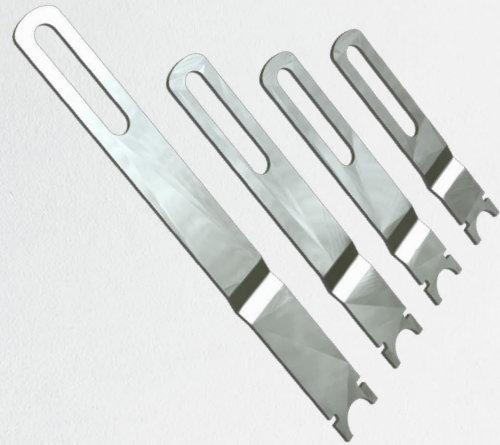

CHANNEL TIE CAVITY KEY

35-59mm	ESCHT-100
60-84mm	ESCHT-125
85-109mm	ESCHT-150
110-134mm	ESCHT-175
135-159mm	ESCHT-200
160-184mm	ESCHT-225
185-209mm	ESCHT-250
210-234mm	ESCHT-275
235-259mm	ESCHT-300



Grade 316 stainless steel is available on request for high corrosion areas.

Recommended Wall Tie and Fixing Screw Vertical Centres, based on 25/14 Channel at 600mm Horizontal Centres

Tie Type	Insulation Thickness ¹ (mm)	Vertical Tie Spacing (mm)	Vertical Fixing Spacing (mm)
1	Max 220	300	225
2	Max 220	450	337.5
3	Max 220	450	337.5/450*
4	Max 220	450	337.5/450*

Notes: Centres shown achieve equivalent tie performances to PD 6697 6.2.2.5 Table 12 (M2 Mortar). *337.5mm centres for insulation thickness's greater than 114mm.

25/14 CHANNEL



The channel features fixing holes for stainless steel screws, and ties should be installed at the recommended vertical intervals for the specific system type.

Ensure the correct hole size is used according to the application. Standard lengths are 2700mm.

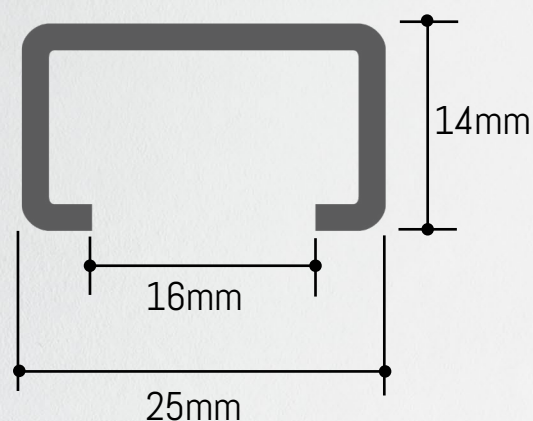

The 25/14 channel is available in 2700mm lengths and features closely spaced pre-punched holes to ensure a fixing position is always near the end, even when cut on-site. The channel has a 16mm opening to easily accommodate washers and fixings.

The 25/14 channel includes alternating 9.7mm and 5.75mm diameter holes to accept different fixings.

Use the smaller diameter holes for fixing to steel or timber, and the larger diameter holes for concrete fixings.

Grade 316 stainless steel is available on request for high corrosion areas.

Note: Using the incorrect hole and fixing screw combination will compromise system performance and irredeemably invalidate the system warranty.

**VISIT THE SITE FOR FURTHER
DOCUMENTATION,
INCLUDING:**



**WARRANTY
DOCUMENT**



**USER
INSTALLATION
GUIDE**



**WARRANTY
QUESTIONNAIRE**

APPLICATION GUIDE

This section will detail the various combinations of stainless-steel compression sleeves and fasteners to be used in variable applications where the insulation thicknesses substrate thickness's and corrosive categories are variable.

Evolution provides a wide range of fastener options which vary depending on the critical contributing factor of substrate thickness.

- The information provided below is intended as a quick reference tool only and the designer should satisfy themselves that the solution, they design for a particular application is suitable for such application.
- When in doubt, or where further assistance is required, please seek further advice by e-mailing technical@evofas.com. Note that parts noted with "*" are by special request only to technical@evofas.com.
- A4 stainless-steel variants with a pancake/ low-profile head are available upon special request to technical@evofas.com.
- **IMPORTANT NOTE:**
When fixing into aluminium a stainless-steel fastener **MUST** be used to avoid electrogalvanic accelerated corrosion.

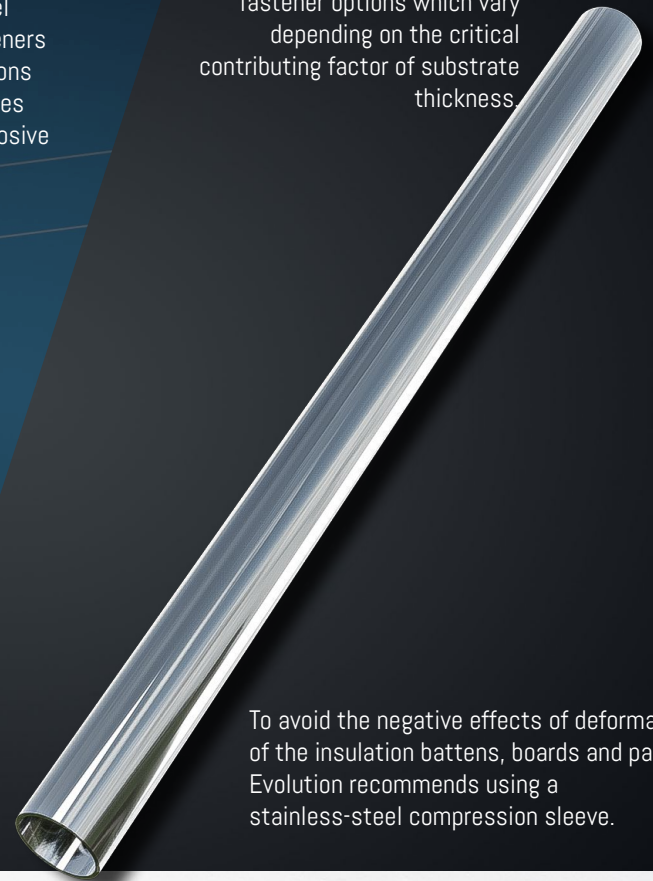

To avoid the negative effects of deformation of the insulation battens, boards and panels, Evolution recommends using a stainless-steel compression sleeve.

LIGHT GAUGE MILD STEEL AND ALUMINIUM SECTIONS AND SUB-STRUCTURES

(1.2mm to 4.0mm Thicknesses)



Washers available in 12/16 mm sizes.

FASTENING INSULATION TO LIGHT GAUGE MILD STEEL OR ALUMINIUM SUBSTRATES

Application			Fastener Solution		
Insulation Thickness, t_{insul} (mm)	Sheathing Board Thickness, t_{board} (mm)	Substrate Thickness, t_{sub} (mm)	Compression Sleeve	Fastener by Corrosivity	
				C3	C4
≤ 50.0	0.0 ≤ 18.0	1.2 ≤ 4.0	SSCS10-50	BMTSBWHT5.5-105-3	A4BMHT105-3
≤ 60.0	0.0 ≤ 18.0	1.2 ≤ 4.0	SSCS10-60	BMTSBWHT5.5-105-3	A4BMHT105-3
≤ 75.0	0.0 ≤ 18.0	1.2 ≤ 4.0	SSCS10-75	BMTSBWHT5.5-115-3	A4BMHT135-3
≤ 80.0	0.0 ≤ 18.0	1.2 ≤ 4.0	SSCS10-80	BMTSBWHT5.5-135-3	A4BMHT135-3
≤ 85.0	0.0 ≤ 18.0	1.2 ≤ 4.0	SSCS10-85	BMTSBWHT5.5-135-3	A4BMHT135-3
≤ 90.0	0.0 ≤ 18.0	1.2 ≤ 4.0	SSCS10-90	BMTSBWHT5.5-135-3	A4BMHT135-3
≤ 100.0	0.0 ≤ 18.0	1.2 ≤ 4.0	SSCS10-100	BMTSBWHT5.5-150-3	A4BMHT150-3
≤ 110.0	0.0 ≤ 18.0	1.2 ≤ 4.0	SSCS10-110	BMTSBWHT5.5-150-3	A4BMHT150-3
≤ 120.0	0.0 ≤ 18.0	1.2 ≤ 4.0	SSCS10-120	BMTSBWHT16-5.5-165-3	A4BMHT185-3
≤ 125.0	0.0 ≤ 18.0	1.2 ≤ 4.0	SSCS10-125	BMTSBWHT16-5.5-165-3	A4BMHT185-3
≤ 130.0	0.0 ≤ 18.0	1.2 ≤ 4.0	SSCS10-130	BMTSBWHT16-5.5-185-3	A4BMHT185-3
≤ 135.0	0.0 ≤ 18.0	1.2 ≤ 4.0	SSCS10-135	BMTSBWHT16-5.5-185-3	A4BMHT185-3
≤ 140.0	0.0 ≤ 18.0	1.2 ≤ 4.0	SSCS10-140	BMTSBWHT16-5.5-185-3	A4BMHT185-3
≤ 150.0	0.0 ≤ 18.0	1.2 ≤ 4.0	SSCS10-150	BMTSBWHT16-5.5-225-3	A4BMHT12-5.5-200-3
≤ 160.0	0.0 ≤ 18.0	1.2 ≤ 4.0	SSCS10-160	BMTSBWHT16-5.5-225-3	A4BMHT12-5.5-200-3
≤ 170.0	0.0 ≤ 18.0	1.2 ≤ 4.0	SSCS10-170	BMTSBWHT16-5.5-225-3	-
≤ 180.0	0.0 ≤ 18.0	1.2 ≤ 4.0	SSCS10-180	BMTSBWHT16-5.5-225-3	-
≤ 200.0	0.0 ≤ 18.0	1.2 ≤ 4.0	SSCS10-200	BMTSBWHT16-5.5-265-3	-
≤ 220.0	0.0 ≤ 18.0	1.2 ≤ 4.0	SSCS10-220	BMTSBWHT16-5.5-265-3	-
≤ 230.0	0.0 ≤ 18.0	1.2 ≤ 4.0	SSCS10-230	BMTSBWHT16-5.5-275-3	-
≤ 240.0	0.0 ≤ 18.0	1.2 ≤ 4.0	SSCS10-240	BMTSBWHT16-5.5-300-3	-

HEAVY GAUGE MILD STEEL AND ALUMINIUM SECTIONS AND SUB-STRUCTURES

FASTENING INSULATION TO LIGHT GAUGE MILD STEEL OR ALUMINIUM SUBSTRATES

Application			Fastener Solution		
Insulation Thickness, t_{insul} (mm)	Sheathing Board Thickness, t_{board} (mm)	Substrate Thickness, t_{sub} (mm)	Compression Sleeve	Fastener by Corrosivity	
				C3	C4
≤ 50.0	0.0 ≤ 18.0	4.0 ≤ 12.0	SSCS10-50	BMTSBWHT5.5-105-5	-
≤ 60.0	0.0 ≤ 18.0	4.0 ≤ 12.0	SSCS10-60	BMTSBWHT5.5-125-5	-
≤ 75.0	0.0 ≤ 18.0	4.0 ≤ 12.0	SSCS10-75	BMTSBWHT5.5-150-5	-
≤ 80.0	0.0 ≤ 18.0	4.0 ≤ 12.0	SSCS10-80	BMTSBWHT5.5-150-5	-
≤ 85.0	0.0 ≤ 18.0	4.0 ≤ 12.0	SSCS10-85	BMTSBWHT5.5-150-5	A4BMHT16-5.5-185-7*
≤ 90.0	0.0 ≤ 18.0	4.0 ≤ 12.0	SSCS10-90	BMTSBWHT5.5-150-5	A4BMHT16-5.5-185-7*
≤ 100.0	0.0 ≤ 18.0	4.0 ≤ 12.0	SSCS10-100	BMTSBWHT5.5-185-5	A4BMHT16-5.5-185-7*
≤ 110.0	0.0 ≤ 18.0	4.0 ≤ 12.0	SSCS10-110	BMTSBWHT5.5-185-5	A4BMHT16-5.5-185-7*
≤ 120.0	0.0 ≤ 18.0	4.0 ≤ 12.0	SSCS10-120	BMTSBWHT5.5-185-5	A4BMHT16-5.5-235-7*
≤ 125.0	0.0 ≤ 18.0	4.0 ≤ 12.0	SSCS10-125	BMTSBWHT5.5-185-5	A4BMHT16-5.5-235-7*
≤ 130.0	0.0 ≤ 18.0	4.0 ≤ 12.0	SSCS10-130	BMTSBWHT5.5-185-5	A4BMHT16-5.5-235-7*
≤ 135.0	0.0 ≤ 18.0	4.0 ≤ 12.0	SSCS10-135	BMTSBWHT5.5-245-5	A4BMHT16-5.5-235-7*
≤ 140.0	0.0 ≤ 18.0	4.0 ≤ 12.0	SSCS10-140	BMTSBWHT5.5-245-5	A4BMHT16-5.5-235-7*
≤ 150.0	0.0 ≤ 18.0	4.0 ≤ 12.0	SSCS10-150	BMTSBWHT5.5-245-5	A4BMHT16-5.5-235-7*
≤ 160.0	0.0 ≤ 18.0	4.0 ≤ 12.0	SSCS10-160	BMTSBWHT5.5-245-5	A4BMHT16-5.5-235-7*
≤ 170.0	0.0 ≤ 18.0	4.0 ≤ 12.0	SSCS10-170	BMTSBWHT5.5-245-5	A4BMHT16-5.5-250-7*
≤ 180.0	0.0 ≤ 18.0	4.0 ≤ 12.0	SSCS10-180	BMTSBWHT5.5-245-5	A4BMHT16-5.5-250-7*
≤ 200.0	0.0 ≤ 18.0	4.0 ≤ 12.0	SSCS10-200	-	A4BMHT16-5.5-275-7*
≤ 220.0	0.0 ≤ 18.0	4.0 ≤ 12.0	SSCS10-220	-	A4BMHT16-5.5-300-7*
≤ 230.0	0.0 ≤ 18.0	4.0 ≤ 12.0	SSCS10-230	-	A4BMHT16-5.5-300-7*
≤ 240.0	0.0 ≤ 18.0	4.0 ≤ 12.0	SSCS10-240	-	-

*Re-washing available on request.



(4.0mm to 12.0mm
thicknesses)

CONCRETE AND MASONRY SUBSTRATES

FASTENING INSULATION TO LIGHT GAUGE MILD STEEL OR ALUMINIUM SUBSTRATES

Application			Fastener Solution		
Insulation Thickness, t_{insul} (mm)	Sheathing Board Thickness, t_{board} (mm)	Embedment Depth t_{sub} (mm)	Compression Sleeve	Fastener by Corrosivity	
				C3	C4
≤ 50.0	0.0 ≤ 18.0	≥ 25.0 ≤ 45.0	SSCS10-50	A4HH6.3-100-GP	A4HH6.3-100-GP
≤ 60.0	0.0 ≤ 18.0	≥ 25.0 ≤ 45.0	SSCS10-60	A4HH6.3-125-GP	A4HH6.3-125-GP
≤ 75.0	0.0 ≤ 18.0	≥ 25.0 ≤ 45.0	SSCS10-75	A4HH6.3-140-GP	A4HH6.3-140-GP
≤ 80.0	0.0 ≤ 18.0	≥ 25.0 ≤ 45.0	SSCS10-80	A4HH6.3-140-GP	A4HH6.3-140-GP
≤ 85.0	0.0 ≤ 18.0	≥ 25.0 ≤ 45.0	SSCS10-85	A4HH6.3-160-GP	A4HH6.3-160-GP
≤ 90.0	0.0 ≤ 18.0	≥ 25.0 ≤ 45.0	SSCS10-90	A4HH6.3-160-GP	A4HH6.3-160-GP
≤ 100.0	0.0 ≤ 18.0	≥ 25.0 ≤ 45.0	SSCS10-100	A4HH6.3-160-GP	A4HH6.3-160-GP
≤ 110.0	0.0 ≤ 18.0	≥ 25.0 ≤ 45.0	SSCS10-110	A4HH6.3-180-GP	A4HH6.3-180-GP
≤ 120.0	0.0 ≤ 18.0	≥ 25.0 ≤ 45.0	SSCS10-120	A4HH6.3-180-GP	A4HH6.3-180-GP
≤ 125.0	0.0 ≤ 18.0	≥ 25.0 ≤ 45.0	SSCS10-125	A4HH6.3-180-GP	A4HH6.3-180-GP
≤ 130.0	0.0 ≤ 18.0	≥ 25.0 ≤ 45.0	SSCS10-130	A4HH6.3-200-GP	A4HH6.3-200-GP
≤ 135.0	0.0 ≤ 18.0	≥ 25.0 ≤ 45.0	SSCS10-135	A4HH6.3-200-GP	A4HH6.3-200-GP
≤ 140.0	0.0 ≤ 18.0	≥ 25.0 ≤ 45.0	SSCS10-140	A4HH6.3-200-GP	A4HH6.3-200-GP
≤ 150.0	0.0 ≤ 18.0	≥ 25.0 ≤ 45.0	SSCS10-150	A4HH6.3-200-GP	A4HH6.3-200-GP
≤ 160.0	0.0 ≤ 18.0	≥ 25.0 ≤ 45.0	SSCS10-160	A4HH6.3-200-GP	A4HH6.3-200-GP
≤ 170.0	0.0 ≤ 18.0	≥ 25.0 ≤ 45.0	SSCS10-170	A4HH6.3-250-GP	A4HH6.3-250-GP
≤ 180.0	0.0 ≤ 18.0	≥ 25.0 ≤ 45.0	SSCS10-180	A4HH6.3-250-GP	A4HH6.3-250-GP
≤ 200.0	0.0 ≤ 18.0	≥ 25.0 ≤ 45.0	SSCS10-200	A4HH6.3-250-GP	A4HH6.3-250-GP
≤ 220.0	0.0 ≤ 18.0	≥ 25.0 ≤ 45.0	SSCS10-220	-	-
≤ 230.0	0.0 ≤ 18.0	≥ 25.0 ≤ 45.0	SSCS10-230	-	-
≤ 240.0	0.0 ≤ 18.0	≥ 25.0 ≤ 45.0	SSCS10-240	-	-

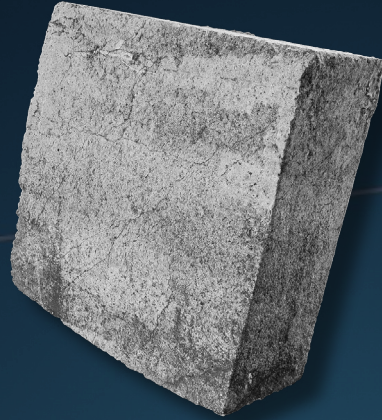

A STAINLESS STEEL COMPRESSION SLEEVE, THE SAME DEPTH AS THE INSULATION, IS REQUIRED AND THE SCREW IS INSTALLED THROUGH THE CHANNEL AND THE COMPRESSION SLEEVE, LOCATED IN THE INSULATION, AND INTO THE PILOT HOLE IN THE CONCRETE FRAME.

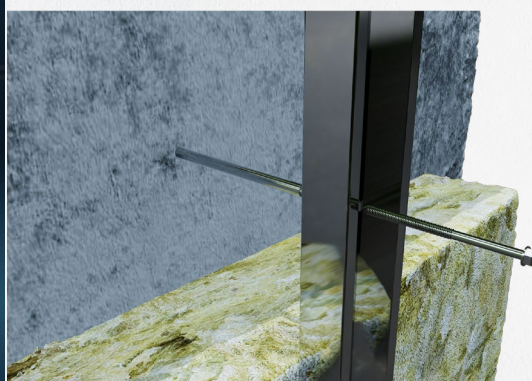

VISIT OUR
WEBSITE
FOR MORE INFORMATION.



VIDEOS
DOCUMENTS
HOW-TO'S
AND MUCH MORE...



BRICK TIE SYSTEM THROUGH LIGHT GAUGE MILD STEEL

The Enterprise Brick-tie system™ is designed to connect the outer leaf of a cavity wall to a light steel frame through mineral wool using an appropriate fixing.

This system comprises several components that work together to form a robust structural restraint assembly.

For light gauge steel frames, the smaller holes are intended for use with high-thread self-drilling fixings.

All fixings used with the Enterprise Brick-tie system™ are made of stainless steel.

At each fixing point, a compression sleeve with high compressive strength ensures a high-capacity fixing detail, accommodating even the thickest insulation used in modern construction.

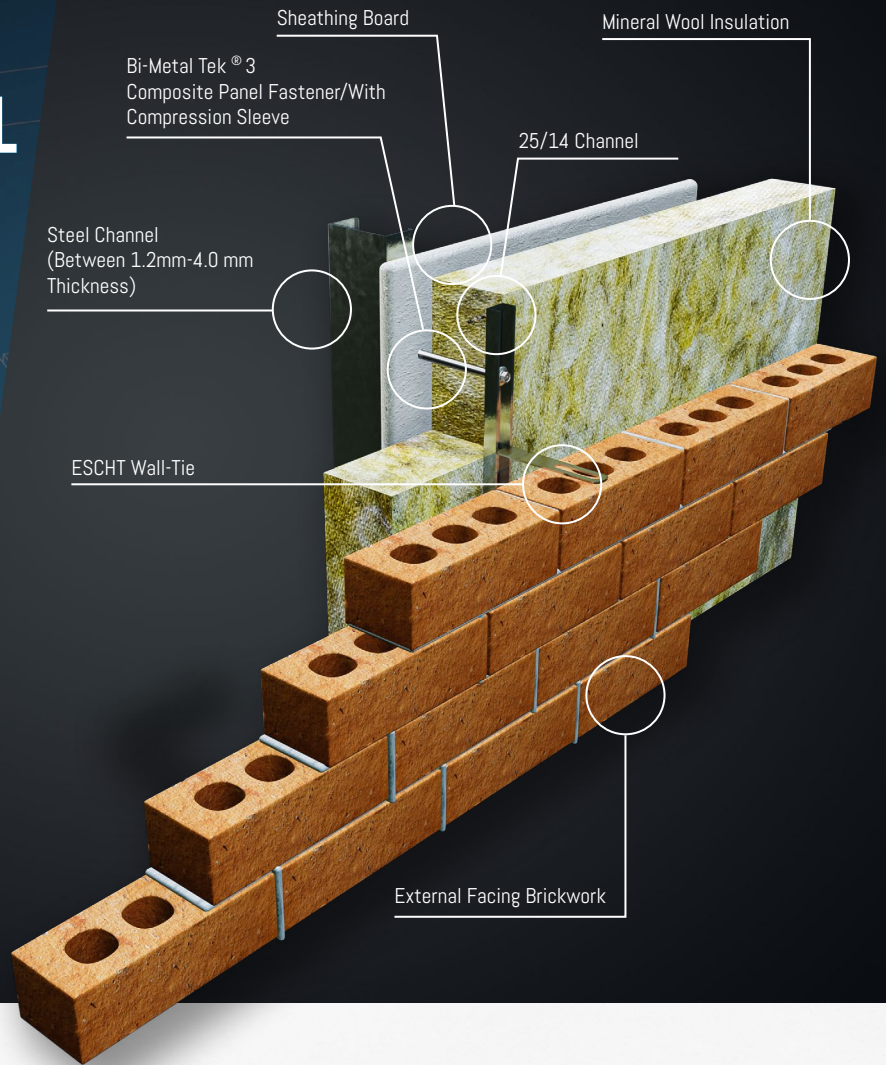

CHARACTERISTIC WITHDRAWAL RESISTANCE, N_{Rk} (N)									
FASTENER PROPERTIES		SUBSTRATE GRADE	SUBSTRATE NOMINAL THICKNESS, t_{sub} (mm)						
MATERIAL	NOM DIA. d_{nom}		1.20	1.60	2.00	2.50	3.00	4.00	
EN 1.4301/ EN 1.4401	5.50	S320GD	1,700	2,100	2,500	3,300	4,100	5,400	
EN 1.4301/ EN 1.4401	5.50	S450JR	2,300	2,900	3,500	4,600	5,700	7,500	

CHARACTERISTIC MECHANICAL PROPERTIES (N)	
CHARACTERISTIC	MAGNITUDE
Tensile capacity, $F_{u,Rk}$	13,300
Shearing resistance, $V_{u,Rk}$	7,900

CHARACTERISTIC PULL-OVER RESISTANCE, $N_{Rk,WASHER}$ (N)	
WASHER DIAMETER, d_{washer}	MAGNITUDE
12.0	8,100
16.0	8,400

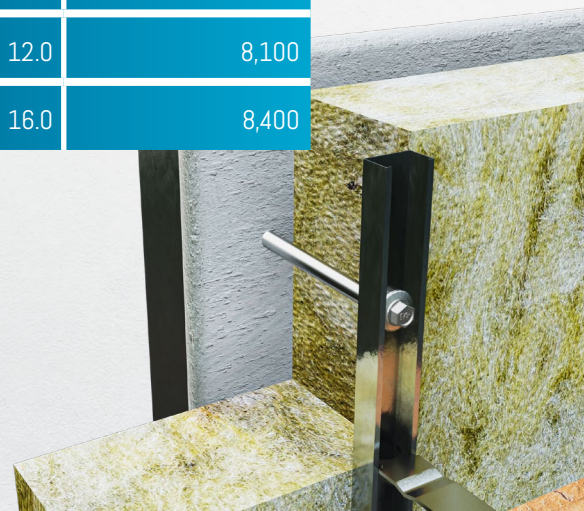

BI-METAL™ COMPOSITE PANEL RANGE

(LIGHT SECTION)

BMTSBWHT
RANGE



FOR LIGHT STEEL	WITH 16mm WASHER	FULL RANGE FROM: 5.5mm-80mm to 300mm
-----------------	------------------	--------------------------------------

CODE:

BMTSBWHT5.5-80-3	BMTSBWHT5.5-105-3	BMTSBWHT5.5-115-3	BMTSBWHT5.5-135-3
BMTSBWHT5.5-150-3	BMTSBWHT5.5-165-3	BMTSBWHT5.5-185-3	BMTSBWHT5.5-200-3
BMTSBWHT5.5-225-3	BMTSBWHT5.5-235-3	BMTSBWHT5.5-275-3	BMTSBWHT5.5-300-3

A2BMHT
RANGE



FOR LIGHT STEEL	WITH NO WASHER	RANGE FROM 5.5mm-125mm to 185mm
-----------------	----------------	---------------------------------

CODE:

A2BMHT5.5-125-3	A2BMHT-5.5-135-3	A2BMHT-5.5-150-3	A2BMHT-5.5-185-3
-----------------	------------------	------------------	------------------

A4BMHT
RANGE



FOR LIGHT STEEL	WITH 16mm WASHER	RANGE FROM 5.5mm - 105mm - 185mm
-----------------	------------------	----------------------------------

CODE:

A4BMHT105-3	A4BMHT135-3	A4BMHT150-3	A4BMHT185-3
-------------	-------------	-------------	-------------



BRICK TIE SYSTEM THROUGH HEAVY GAUGE MILD STEEL

The Enterprise Brick-tie system™ is designed to connect the outer leaf of a cavity wall to a heavy steel frame through mineral wool using an appropriate fixing.

This system comprises several components that work together to form a robust structural restraint assembly.

For heavy gauge steel frames, the smaller holes are intended for use with high-thread self-drilling fixings, made for heavy steel.

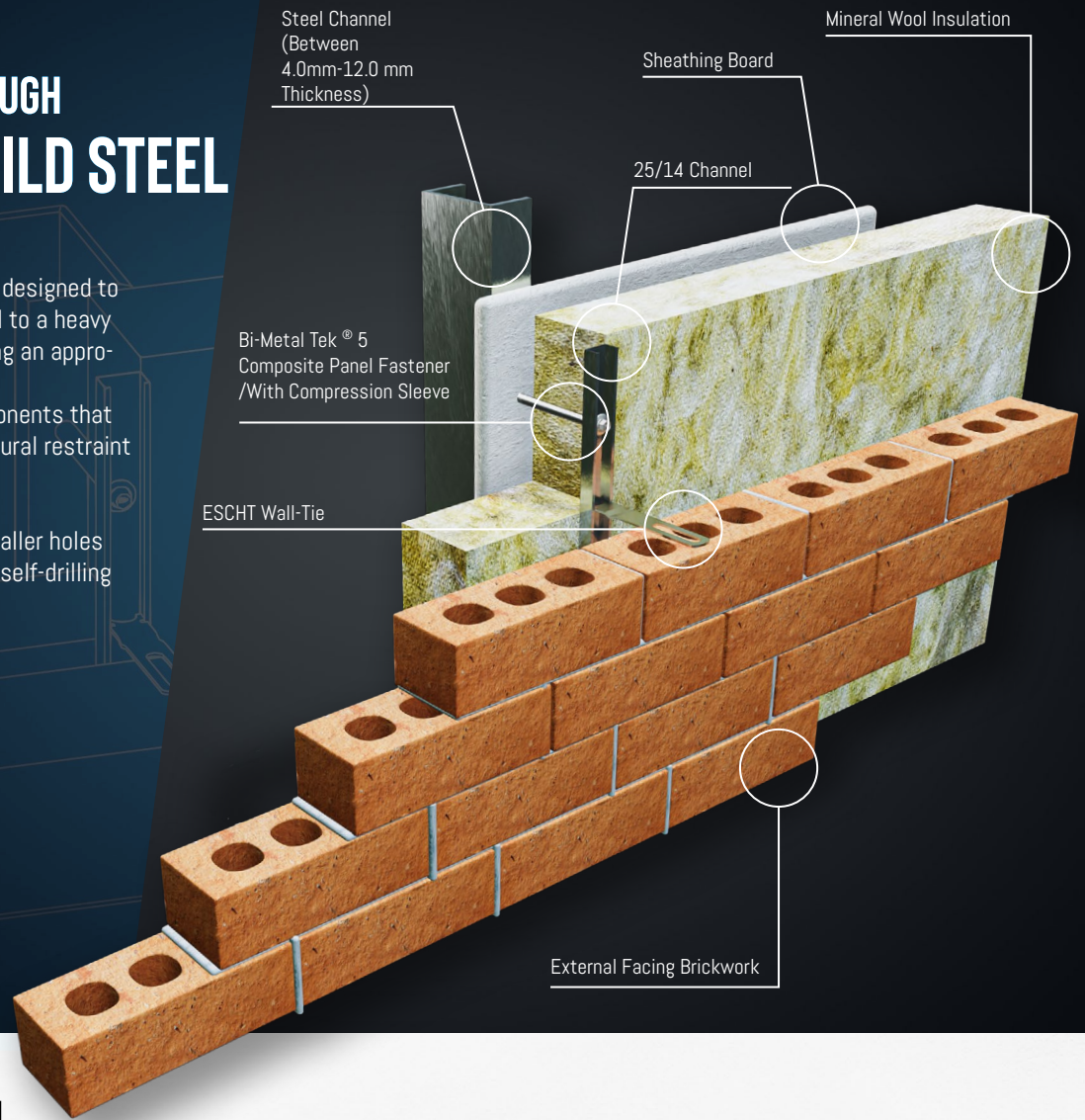

INSTALLATION

1. OFFER UP CHANNEL TO MATCH SLEEVE LOCATIONS.

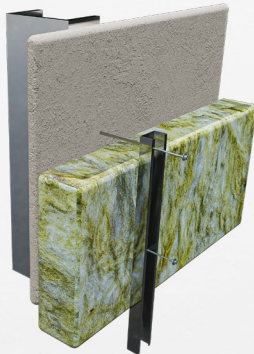

2. INSTALL FIXING THROUGH CHANNEL AND SLEEVE BACK TO INTERNAL STRUCTURE.

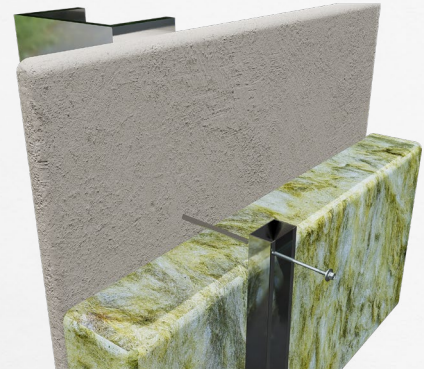

3. ROTATE ESCHT WALL TIE INTO CHANNEL LIPS.



4. EMBED TIE INTO MORTAR JOINT.



BI-METAL™ COMPOSITE PANEL RANGE (HEAVY SECTION)

BMTSBWHT
RANGE

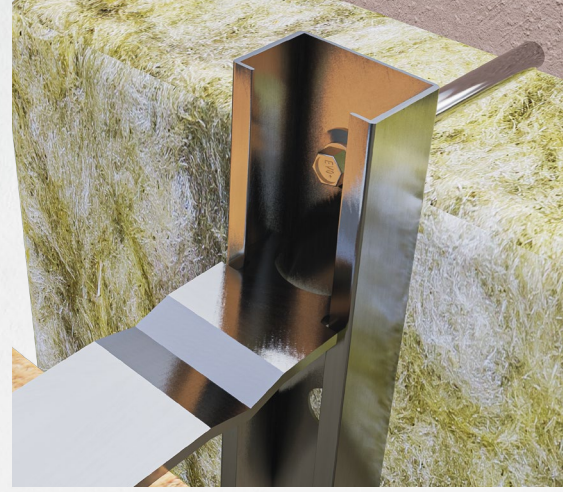
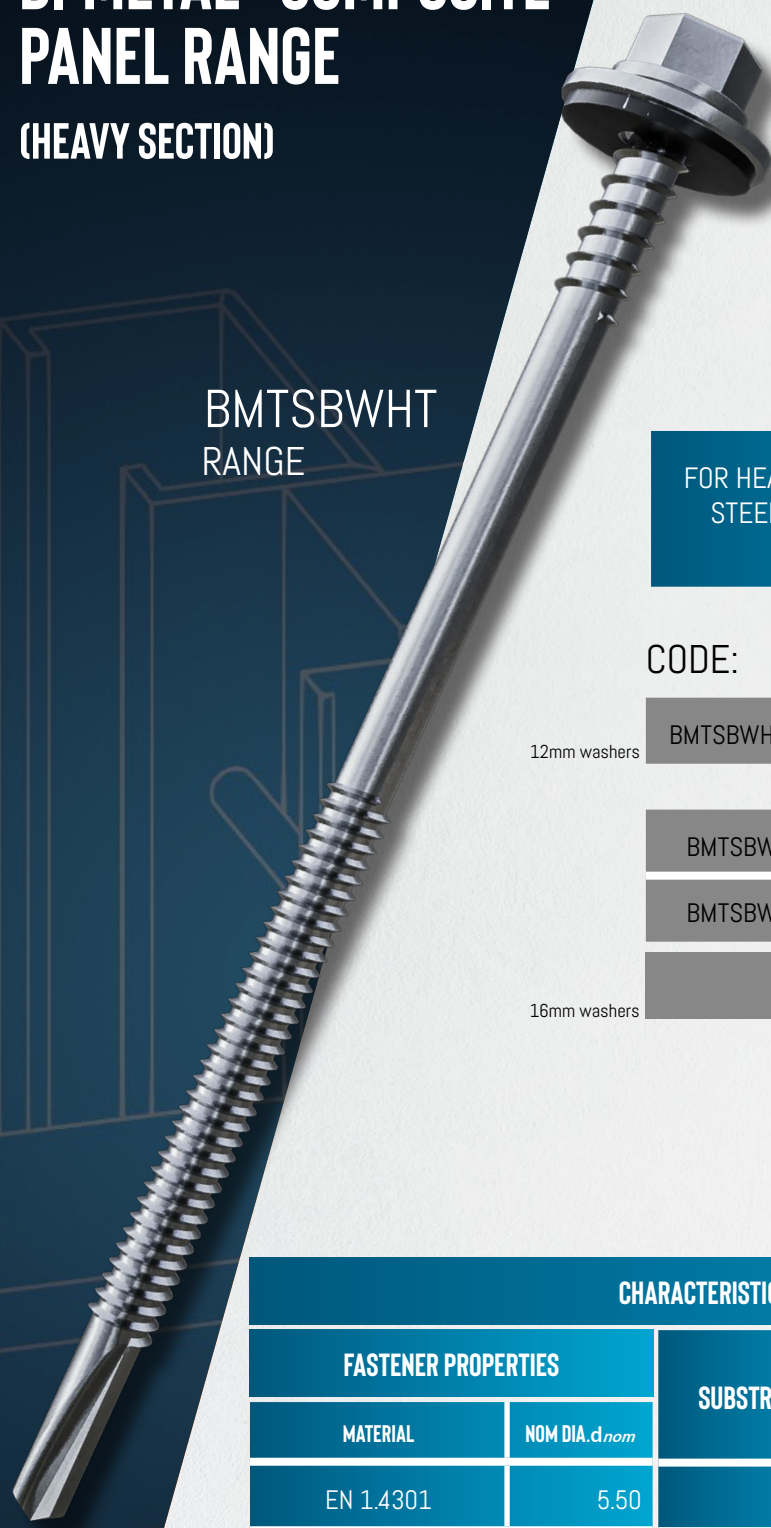

FOR HEAVY STEEL	WITH 12/16mm WASHER	RANGE FROM 5.5mm- 105mm to 245mm
--------------------	---------------------------	--

CODE:

12mm washers	BMTSBWHT12-5.5-185-5	BMTSBWHT12-5.5-245-5
	BMTSBWHT5.5-105-5	BMTSBWHT5.5-125-5
16mm washers	BMTSBWHT5.5-150-5	BMTSBWHT16-5.5-185-5
	BMTSBWHT16-5.5-245-5	

CHARACTERISTIC WITHDRAWAL RESISTANCE, N_{Rk} (N)

FASTENER PROPERTIES		SUBSTRATE GRADE	SUBSTRATE NOMINAL THICKNESS, t_{sub} (mm)					
MATERIAL	NOM DIA. d_{nom}		4.00	5.00	6.00	8.00	10.00	12.00
EN 1.4301	5.50	S320GD	6,400	7,700	10,100	11,400	12,300	13,300
EN 1.4301	5.50	S450JR	8,300	10,000	12,800	13,300	13,300	13,300

CHARACTERISTIC MECHANICAL PROPERTIES (N)

CHARACTERISTIC	MAGNITUDE
Tensile capacity, $F_{u,Rk}$	13,300
Shearing resistance, $V_{u,Rk}$	7,900

CHARACTERISTIC PULL-OVER RESISTANCE, $N_{Rk,WASHER}$ (N)

WASHER DIAMETER, d_{washer}	MAGNITUDE
12.0	8,100
16.0	8,400

BRICK TIE SYSTEM THROUGH SUPER - HEAVY GAUGE MILD STEEL

The Enterprise Brick-tie system™ is designed to connect the outer leaf of a cavity wall to a super heavy steel frame through mineral wool using an appropriate fixing.

This system comprises several components that work together to form a robust structural restraint assembly.

For super-heavy gauge steel frames, the SuperTEK® 7 composite panel fastener/With Compression Sleeve is recommended.

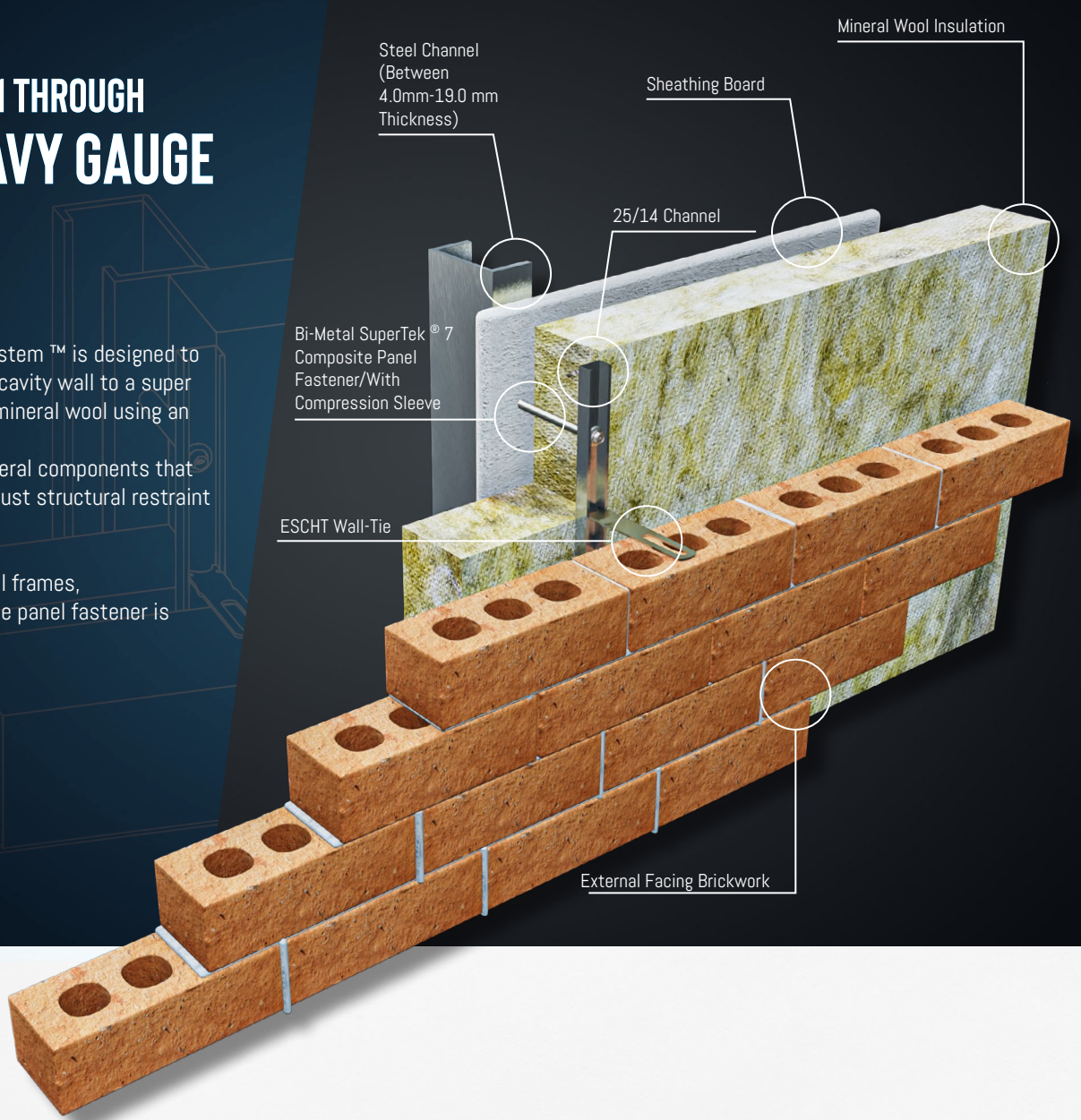

SuperTEK® 7 double-helical point consistently provides industry-leading drilling performance due to its aggressive rake and flank angling and honed blade-edge. This product will self-drill and self-tap in mild steels from 4.0 mm to 18.0 mm in overall thickness.

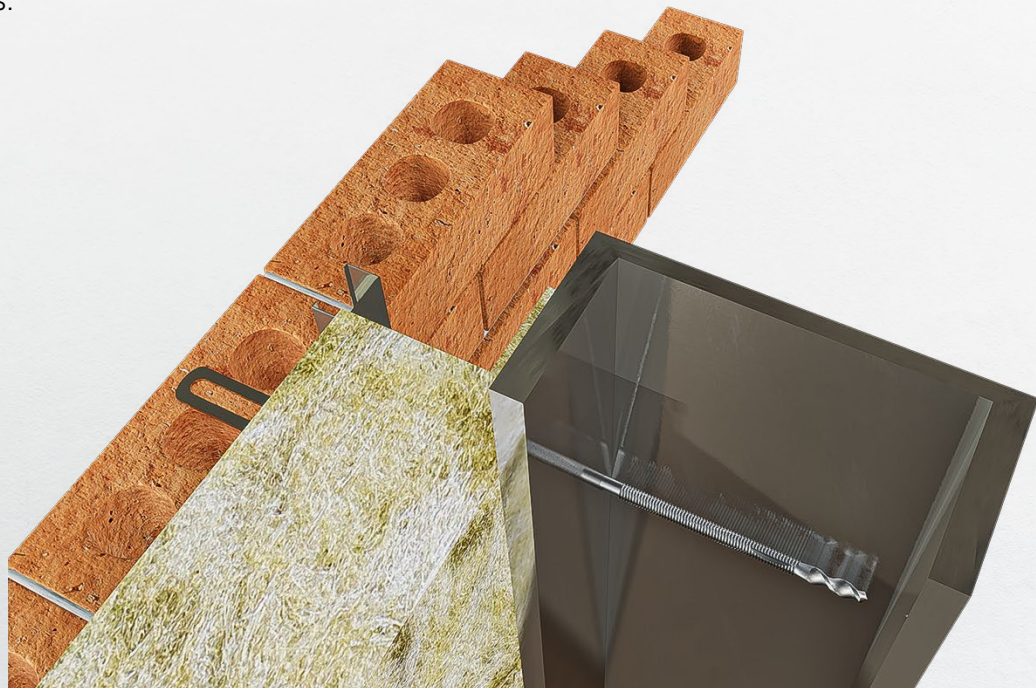

BI-METAL™ SuperTEK® 7 COMPOSITE PANEL RANGE (SUPER-HEAVY SECTION)

A4BMHT16
RANGE

FOR SUPER-HEAVY STEEL	A4 GRADE	RANGE FROM: 5.5mm- 185mm to 300mm
-----------------------------	----------	---

CODE:

A4BMHT16-5.5-185-7*	A4BMHT16-5.5-235-7*
A4BMHT16-5.5-250-7*	A4BMHT16-5.5-275-7*
A4BMHT16-5.5-300-7*	

Especially suited to fixing brick ties, components, bracketry and secondary frame elements/ sections to primary and secondary steel framing where a weather sealing washer is required.

1.06mm (24 TPI) fine thread pitches ensure that maximum positive thread engagement with substrates is achieved.

Note that parts noted with "*" are by special request only to technical@evofas.com.

CHARACTERISTIC WITHDRAWAL RESISTANCE, N_{Rk} (N)

FASTENER PROPERTIES		SUBSTRATE GRADE	SUBSTRATE NOMINAL THICKNESS, t_{sub} (mm)					
MATERIAL	NOM DIA. d_{nom}		4.00	5.00	6.00	8.00	10.00	12.00
EN 1.4301	5.50	S320GD	6,400	7,700	10,100	11,400	12,300	13,300
EN 1.4301	5.50	S450JR	8,300	10,000	12,800	13,300	13,300	13,300

CHARACTERISTIC MECHANICAL PROPERTIES (N)

CHARACTERISTIC	MAGNITUDE
Tensile capacity, $F_{U,Rk}$	13,300
Shearing resistance, $V_{U,Rk}$	7,900

CHARACTERISTIC PULL-OVER RESISTANCE, $N_{Rk,WASHER}$ (N)

WASHER DIAMETER, d_{washer}	MAGNITUDE
16.0	8,400

BRICK TIE SYSTEM THROUGH CONCRETE

The Enterprise Brick-tie system™ is designed to connect an outer leaf of a masonry cavity wall to a concrete frame or another structural element through mineral wool using an appropriate fixing. This system comprises several components that work together to form a robust structural restraint assembly.

It features numerous pre-punched holes spaced closely together, allowing for flexible fixing points based on the application. For concrete applications, the larger holes are intended for use with stainless steel masonry fixings.

At each fixing point, a compression sleeve with high compressive strength ensures a high-capacity fixing detail, accommodating even the thickest insulation used in modern construction.

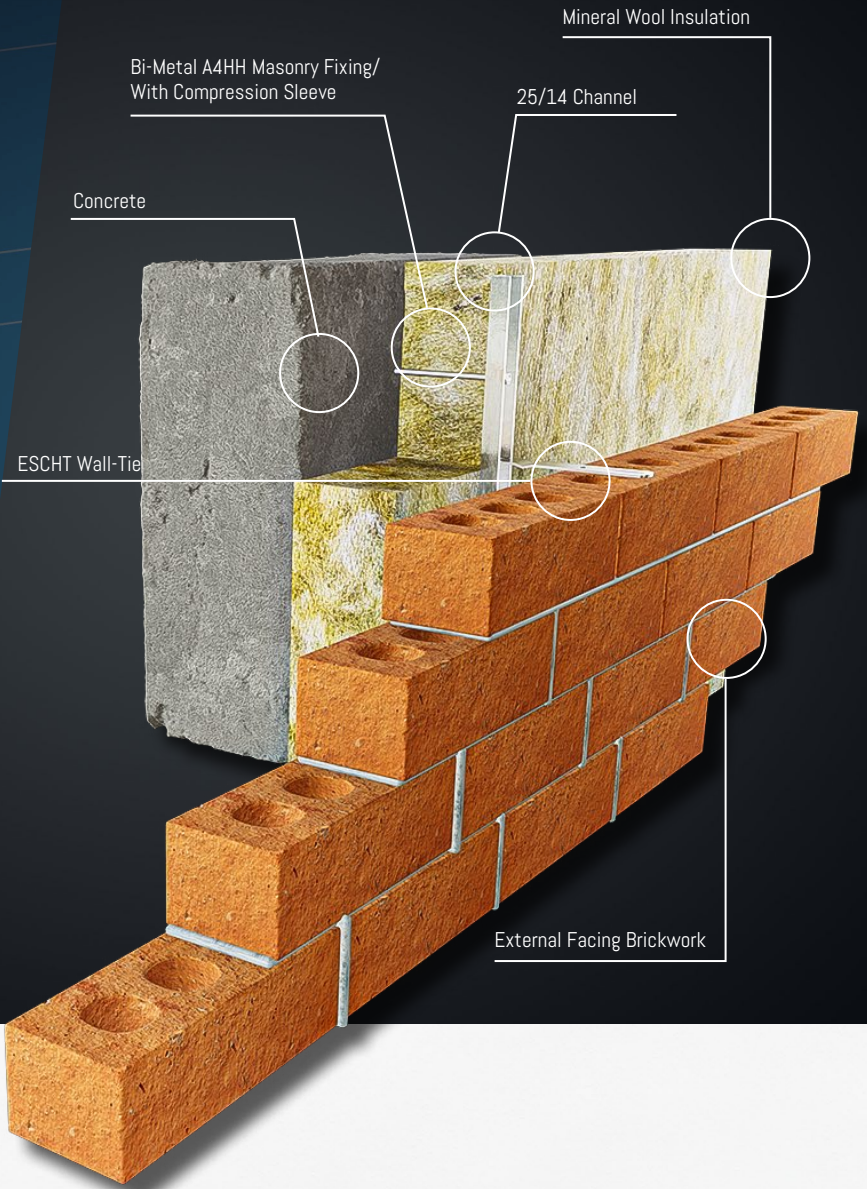

INSTALLATION

1. DRILL PILOT HOLE
(SEE TABLE ON NEXT PAGE).



2. INSTALL FIXING THROUGH CHANNEL AND SLEEVE BACK TO INTERNAL STRUCTURE.

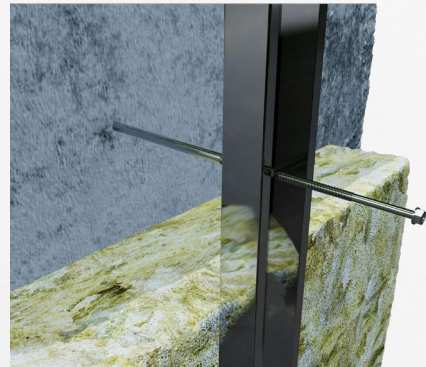

3. ROTATE ESCHT WALL TIE INTO CHANNEL LIPS.



4. EMBED TIE INTO MOTAR JOINT.



BI-METAL™ MASONRY RANGE

A4HH RANGE

FOR CONCRETE	A4 GRADE	RANGE FROM: 6.3mm- 32mm to 250mm
--------------	----------	--

CODE:

A4HH6.3-32-GP	A4HH6.3-45-GP	A4HH6.3-57-GP	A4HH6.3-70-GP
A4HH6.3-82-GP	A4HH6.3-100-GP	A4HH6.3-125-GP	A4HH6.3-140-GP
A4HH6.3-160-GP	A4HH6.3-180-GP	A4HH6.3-200-GP	A4HH6.3-250-GP

CHARACTERISTIC WITHDRAWAL RESISTANCE, N_{Rk} (N)			
EMBEDMENT DEPTH, t_{sub} (mm)	SUBSTRATE TYPE		
	CONCRETE (35 MPa)	BLOCK (7 MPa)	BRICK (7.5 MPa)
25.0	3,900	2,700	4,200
40.0	5,700	3,900	5,900

CHARACTERISTIC MECHANICAL PROPERTIES (N)	
CHARACTERISTIC	MAGNITUDE
Tensile capacity, $F_{u,Rk}$	14,100
Shearing resistance, $V_{u,Rk}$	8,500

CHARACTERISTIC PULL-OVER RESISTANCE, $N_{Rk,WASHER}$ (N)	
WASHER DIAMETER, d_{washer}	MAGNITUDE
16.0	8,400

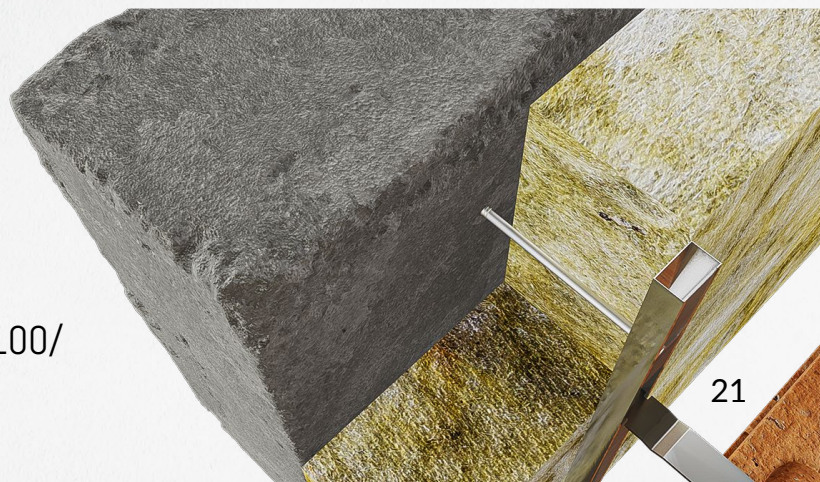

T: +44 (0)141 647 7100/

E:sales@evofas.com



Technical Consultancy Services

In addition to manufacturing and distributing a wide range of premium quality fasteners, we also offer Technical Consultancy Services to support our products including the design and manufacture of bespoke fasteners.



We Believe In FREE

Our expert team of structural, civil, mechanical, and chemical engineers are always on hand to offer FREE assistance and help when specifying or using our products.

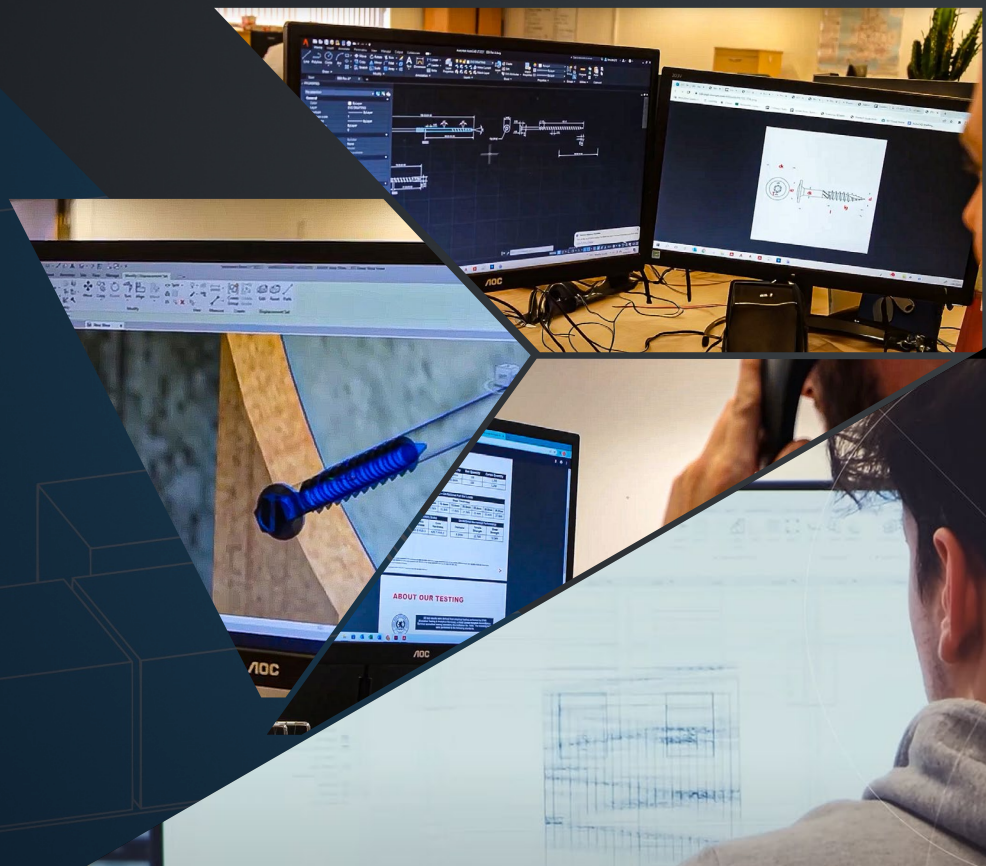

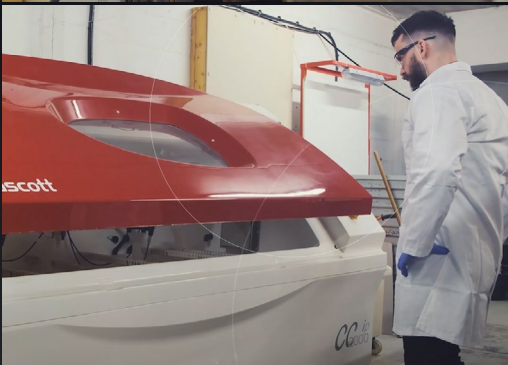

	DWSZ 4.2mm(sec)	DWSZ 4.2mm(N-m)
1	02.51	1.057
2	00.80	1.221
3	00.50	1.125
4	00.49	1.177
5	01.50	0.766
6	01.69	1.188
7	00.67	1.312

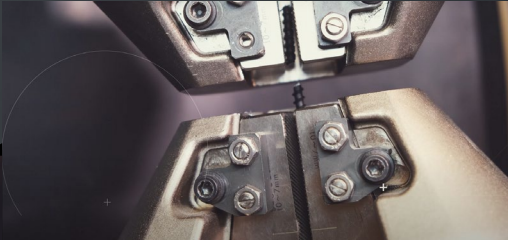

QUALITY ASSURANCE AND LABORATORY TESTING

We operate a UKAS accredited testing laboratory, uniquely designed to test all aspects of construction fixings and fasteners as well as other tests suited to the aerospace, automotive, oil & gas, and marine industries.

Our Most Sought After Services:

TENSILE, SHEAR, FATIGUE AND DEFLECTION TESTING

TORQUE TESTING

FAILURE ANALYSIS (hydrogen embrittlement, stress corrosion etc)

METALOGRAPHY (hardness - vickers/rockwell, HAZ etc)

MICROSCOPY (light, metallographic etc)

CORROSION TESTING (neutral salt spray, cyclic corrosion etc)



Premium quality is something we take very seriously at Evolution and our ISO 9001 certification demonstrates this. We are dedicated to ensuring quality in everything we do, from our products to our Customer Services and Marketing Support.



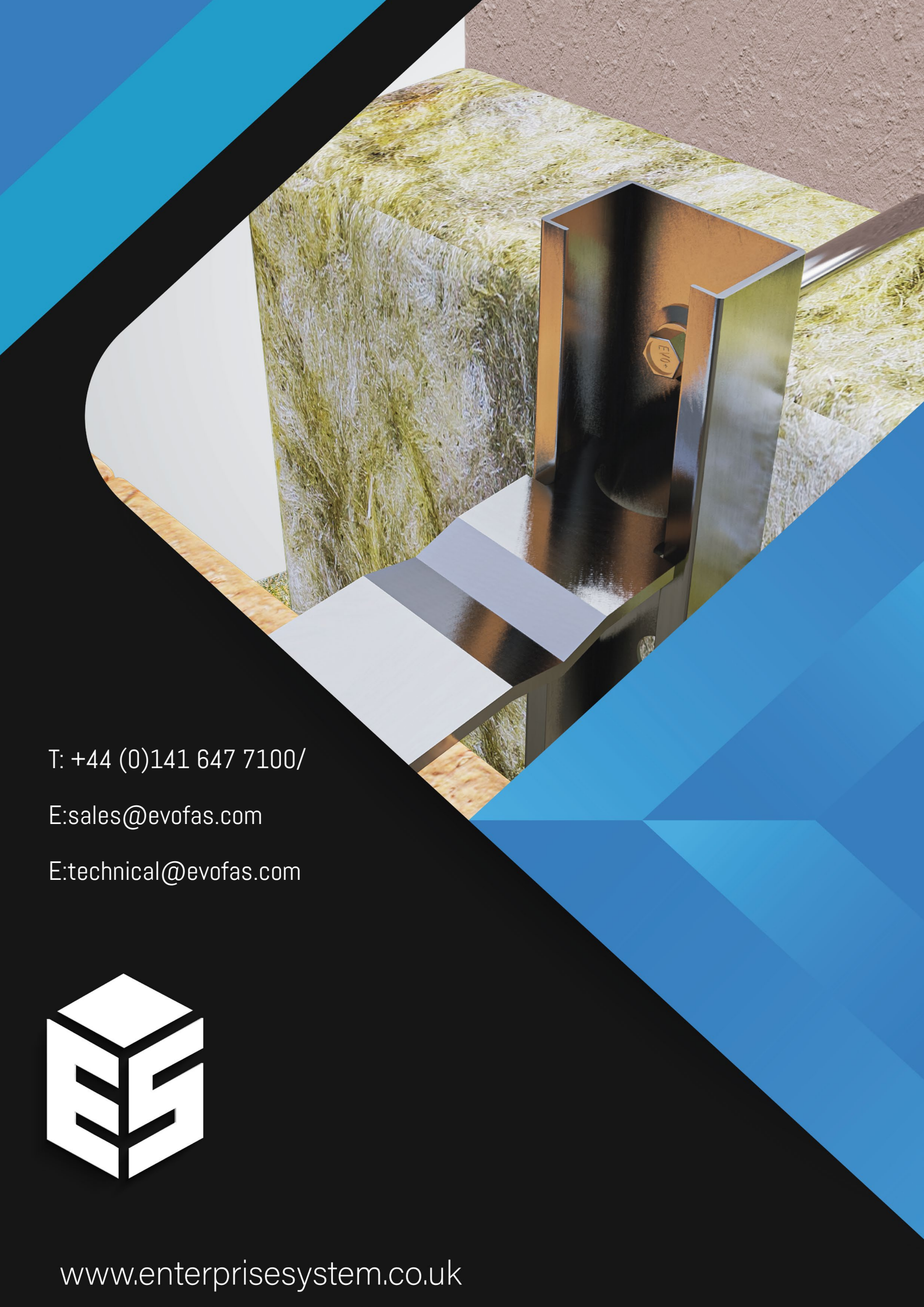

T: +44 (0)141 647 7100/

E:sales@evofas.com

E:technical@evofas.com



www.enterprisesystem.co.uk